



Piston valves KVN KX-GT

CE 0408
Conformity with Pressure
Equipment Directive 97/23/EC



KLINGER piston valves

Application examples



KLINGER piston valves

Advantages and summary of types

KVN Advantages

- **Reliably tight – across the ports and to the atmosphere**
- **Environmentally safe and energy efficient**
- **Asbestos-free**
- **No erosion on the sealing surfaces**
- **Insensitive to impurities due to maintenance-free sealing system**
- **Unbeatable in a comparison of profitability**
- **Maintenance-free**
- **Easy to install**
- **Valve rings are replaceable in the line**
- **Excellent control characteristics**
- **Fire-safe tested according to API 6FA**
- **Inspected according to EPA-emission-test**
- **Conforms to TA-Luft**
- **VdTÜV license 1065 type approval**
- **Suitable for oxygen (BAM)**

KVN 10–50 m.c. III, VI, VIII, Xc

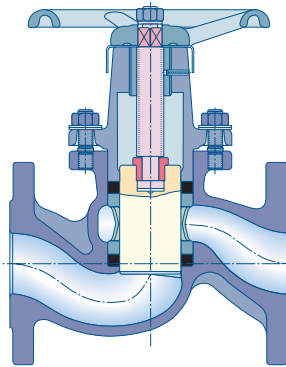

KVN 65–150 m.c. III

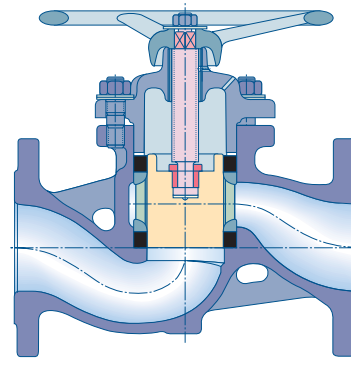

KVNB 65–200 m.c. III

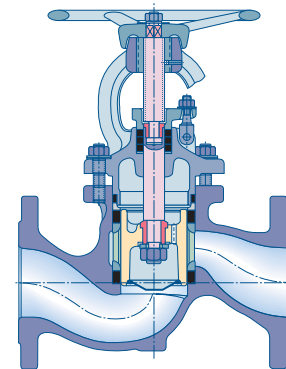

KVN 65–200 m.c. VI, VIII

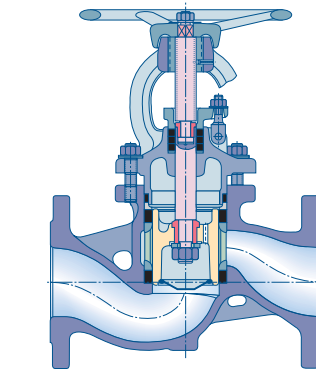

KVMN 1/2"–2" m.c. III, VIII, Xc

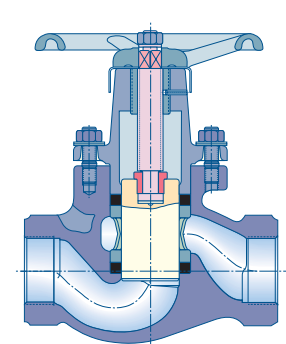

KVSN 1/2"–2" m.c. VIII

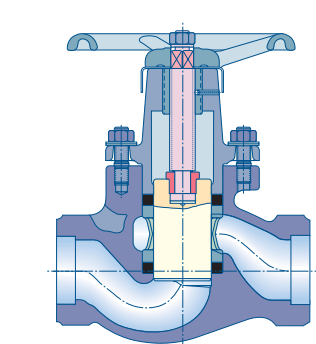

KVSN 15–50 m.c. VIII

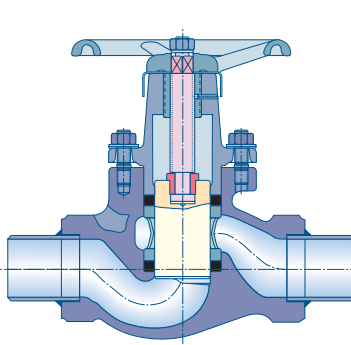

TÜV
ZERTIFIKAT

Das TÜV CERT-Zertifizierungsstelle
des TÜV Österreich
bestätigt gemäß
TÜV CERT-Verfahren, dass das Unternehmen

KLINGER
Firma Klinger

A-CERT Qualitätszertifikat
für den Geltungsbereich

Herstellung, Montage und Vertrieb
von Industriemaschinen und Schweißtechnik

ein Qualitätsmanagementsystem eingeführt hat
und anwendet.

Durch ein Audit, Bericht Nr. 2016019,
wurde der Nachweis erbracht, dass die Fertigung der

EN ISO 9001:2008

erfüllt und dieses Zertifikat im gültigen (04.01.2016)

Zertifikat Nummer Nr. 20 150 0410



TÜV
ÖSTERREICH





KLINGER piston valves

Optimization through experience



Piston valves KVN

Excellent ideas are lasting

In the year 1922 Richard KLINGER the founder of this company had an idea, the principle of which is still valid today. He designed the first piston valve. He replaced the sealing system of a conventional globe valve with a cylindrical piston and two elastic replaceable jointing rings.

Environmentally safe and energy efficient

Constant research and further development yield a quality, which comes through brilliantly in extreme applications and is marked by the slightest of leak rates. KLINGER piston valves are the best solution in hot water-, steam-, heat transfer medium- and dry gas application.

Tested and certified

KLINGER KVN piston valves have been tested by independent research institutes under the toughest conditions.

They passed the Fire-safe test according to API 6FA as well as the Helium-leakage test with best results. These results impressively prove the exceptional efficiency of KLINGER piston valves.

Today, piston valves are manufactured based on the state of the art technique and according to the highest quality requirements of ISO 9001.

Efficiency and reliability

The sealing element is formed by two elastic valve rings enveloping a stainless steel piston. The upper valve ring seals to the outside, the lower ring seals across the port. Due to the large piston skirt the sealing effect is optimal. As the valve closes the piston removes impurities which the medium might contain from the inside of the lower valve ring. In this way the valve reliably seals off even contaminated media. In principle, damage to the sealing surface is precluded and tightness is guaranteed as a result.

Excellent control characteristics

The standard version of the KLINGER piston valve is already very well suited for controlling the flow. Because the piston is guided by the upper and the lower valve ring vibration and instability in the pipe does not occur. KLINGER piston valves have proved to be excellent as by-pass control valves.

Through simple replacement of the piston and the lantern bush the KVN can be retrofitted to act as a special precision control valve.

In-line valve ring replacement

A newly installed piston valve does not require any maintenance for a long time after. However, the spindle should be regularly lubricated. If nevertheless a valve ring wears out it can be replaced without problems while remaining in the line and, if assembly instructions are followed, it can be changed by in-house personnel.

After replacement the valve is like new.

KX-GT: Competitiveless in sealing

Environmentally safe and energy efficient

The core of the piston valve: The valve rings KX-GT

The high quality valve ring KX-GT is made of graphite laminate with tang metal sheet inserts made of stainless steel. The valve is absolutely asbestos- and maintenance-free. The variable thermal expansions which occur under alternating thermal loads are completely compensated by KX-GT-valve rings, which were presealed in a built-in condition.

Long term sealing even at highest demands

Media in the temperature range between $-40\text{ }^{\circ}\text{C}$ and $+400\text{ }^{\circ}\text{C}$ and at pressures of up to 63 bar, can be reliably controlled. KX-GT valve rings are excellent for the use in temperature shock operation as well as steam condensate alternating-operation. (Flash-application).

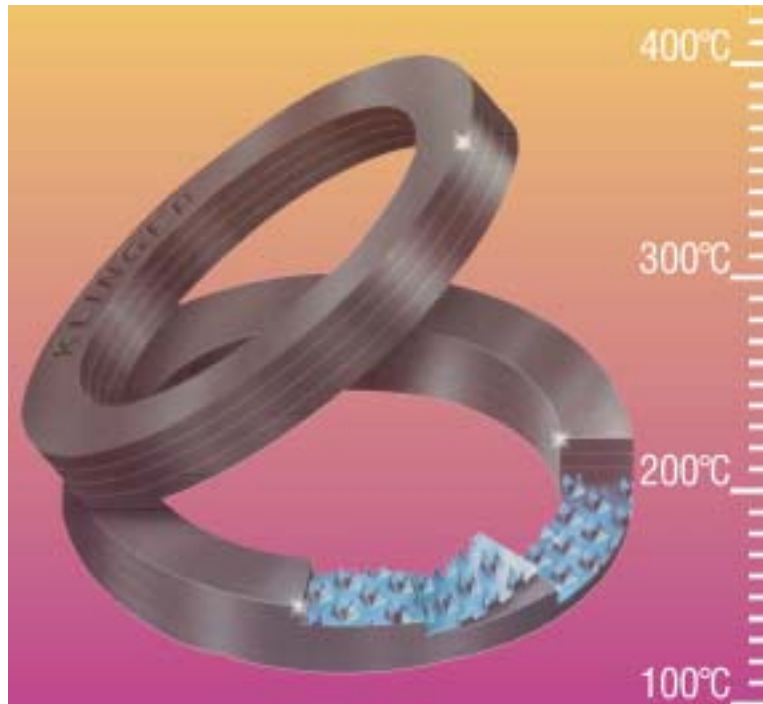

Pressure relieved piston

In order to ensure convenient actuation at high differential pressures, the pistons of the KVN range are made of cast steel, whereof the sizes DN 65 to 200

are pressure relieved. The spindle is sealed with a gland and an additional valve ring provides the sealing between the body and the bonnet.

Cost justification

Piston valve – seat valve – bellows seal valve

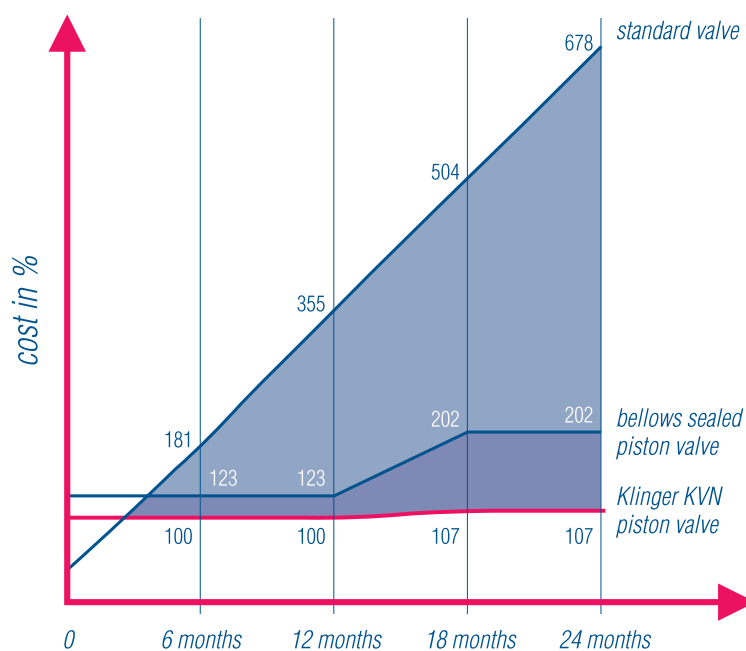



Actuators for KVN

Electro mechanical and pneumatic actuators

Electro mechanical actuator Various designs at request

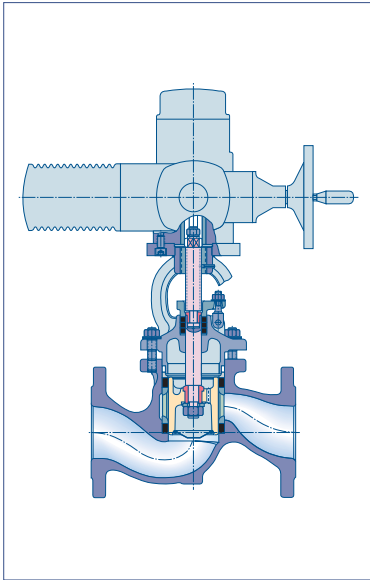

Pneumatic actuator

The pneumatic actuator is single acting and offers an ON/OFF-function. It is often preferred to the electro mechanical actuator for many reasons.

The actuator closes the valve with spring force (security !) and opens it with air pressure. Safe control media are compressed air and nitrogen at a maximum of 6 bar. Compressed air supply: R 1/4", measurement, weight and valve lift at request.

Pneumatic actuators can be applied at ambient temperatures between $-30\text{ }^{\circ}\text{C}$ and $+90\text{ }^{\circ}\text{C}$. The standard version includes pneumatic diaphragm actuator, end switch, stroke scale and a mechanical valve lifting stop. Special design with hand emergency-switch is available.

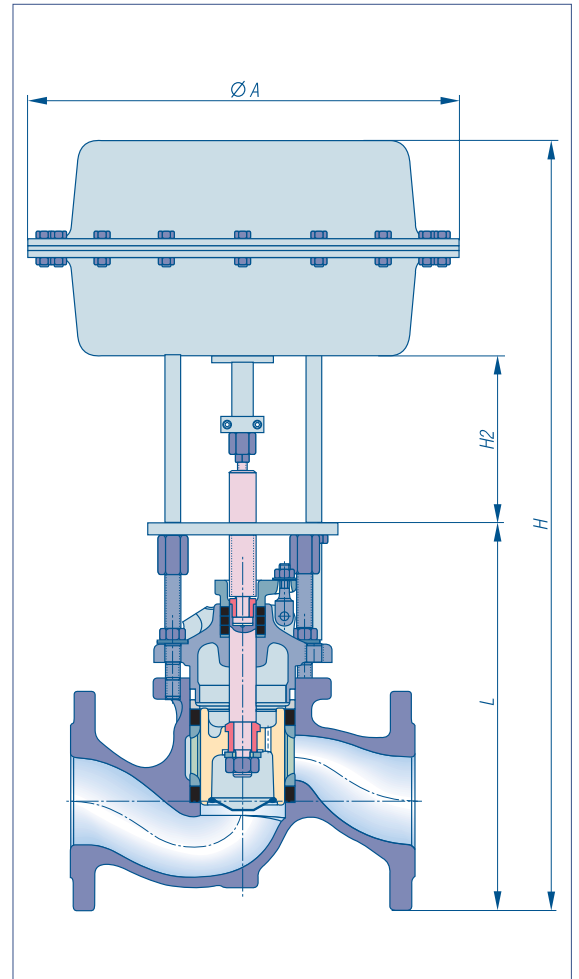
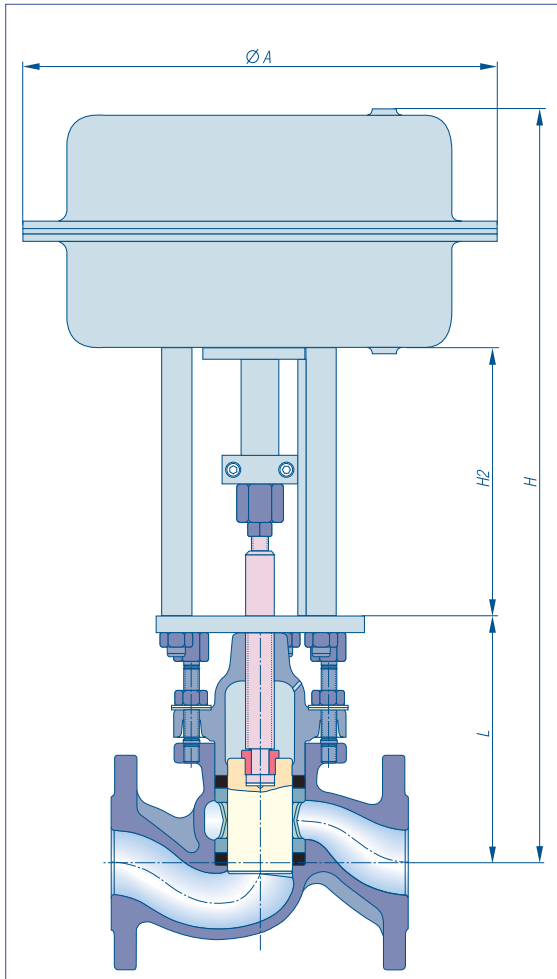

KLINGER piston valves

Technical data

Type	DN	PN	material	connection	overall length	page
KLINGER flanged-valves						
KVN	32–50	6	cast iron	EN 1092-2	EN 558-1 GR1	8
KVN	65–150	6	cast iron	EN 1092-2	EN 558-1 GR1	9
KVN	15–50	16	cast iron	EN 1092-2	EN 558-1 GR1	8
KVN	65–150	16	cast iron	EN 1092-2	EN 558-1 GR1	9
KVNB	65–150	16	cast iron	EN 1092-2	EN 558-1 GR1	10
KVN	65–200	16	spheroidal cast iron	EN 1092-2	EN 558-1 GR1	11
KVN	10–50	40	spheroidal cast iron	EN 1092-2	EN 558-1 GR1	8
KVN	10–50	40	cast steel	EN 1092-1	EN 558-1 GR1	8
KVN	10–50	40	stainless steel	EN 1092-1	EN 558-1 GR1	8
KVN	65–200	40	cast steel	EN 1092-1	EN 558-1 GR1	11
KLINGER valves with female screwed ends						
KVMN	1/2"–2"	16	cast iron	ISO 228-1	DIN 3202-M9	12
KVMN	1/2"–2"	16	cast iron	NPT-thread ANSI B 2.1	DIN 3202-M9	12
KVMN	1/2"–2"	63	cast steel	ISO 228-1	DIN 3202-M9	12
KVMN	1/2"–2"	63	cast steel	NPT-thread ANSI B 2.1	DIN 3202-M9	12
KVMN	1/2"–2"	63	stainless steel	ISO 228-1	DIN 3202-M9	12
KVMN	1/2"–2"	63	stainless steel	NPT-thread ANSI B 2.1	DIN 3202-M9	12
KLINGER valves with weld ends						
KVSN	1/2"–2"	63	cast steel	EN 12 760	DIN 3202-M9	13
KVSN	15–50	63	cast steel	EN 12 627		14
Pressure/temperature-diagrams						15
Connection dimensions						16
Material code						16
Technical data						17
Special design						
Piston valve with heating jacket						
KVN	10–200					18
Piston valve for Fire-safe application						
KVN	10–200					18
Piston valve for TA-Luft and EPA application						
KVN	10–200					20
Certifications						20





Piston valves KVN

Flange acc. to EN 1092-2 PN 16, flange acc. to EN 1092-1 PN 40
 Material: cast iron, spheroidal cast iron, cast steel, stainless steel
 valve ring KX-GT

KVN 10 – 50

PN 40

DN 10–50
 material code VI, VIII, Xc

PN 16

DN 15–50
 material code III

PN 6

DN 32–50
 material code III

**overall length
 acc. to EN 558-1
 Grundreihe 1**

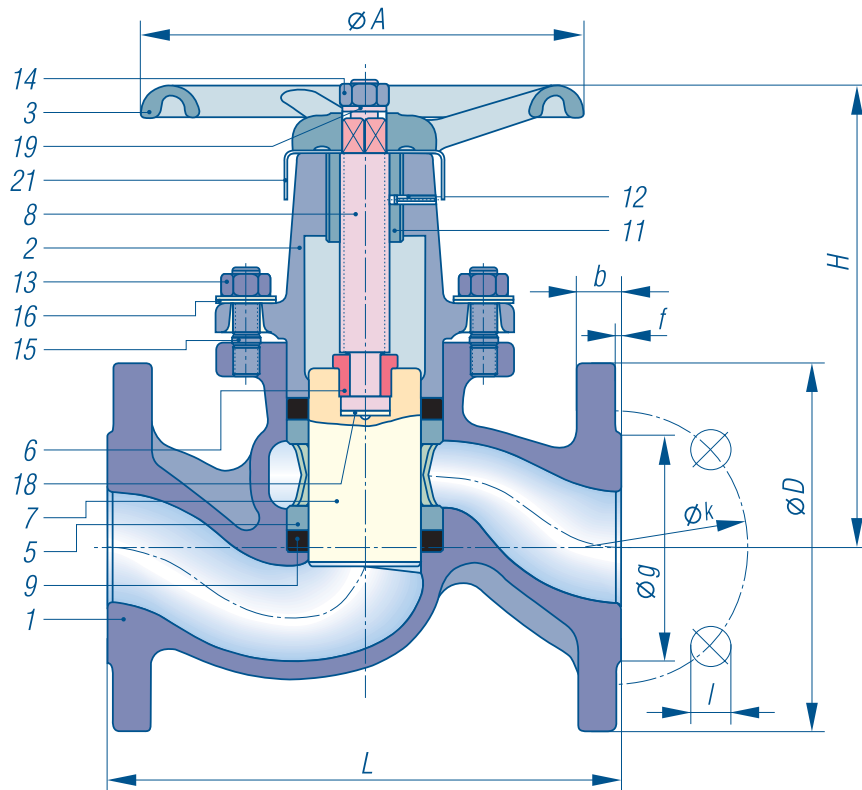

Pressure and temperatur limits see page 15
 Material code and flange dimension see page 16

Part name	Material code			
	III	VI	VIII	Xc
1 Body	EN-GJL-250	EN-JS 1025	1.0619	1.4581
2 Bonnet	EN-GJL-250	EN-JS 1025	1.0460	1.4581
3 Handwheel	EN-GJL-200	EN-GJL-200	EN-GJL-200	EN-GJL-200 ²⁾
5 Lantern bush	Sint C10	Sint C10	Sint C10	1.4408
6 Split nut	1.0715 gal	1.0715 gal	1.0715 gal	1.4571
7 Piston	1.4104	1.4104	1.4104	1.4404
8 Spindle	1.4021	1.4021	1.4021	1.4404
9 Upper valve ring	KX-GT	KX-GT	KX-GT	KX-GT
11 Threaded bush ¹⁾	–	Sint C11	Sint C11	1.4401
12 Tension pin ¹⁾	–	spring steel	spring steel	1.4305
13 Bonnet nut	1.1181	1.1181	1.1181	A4
14 Handwheel nut	1.1181	1.1181	1.1181	A4
15 Stud bolt KVN10–25	1.1181	1.1181	1.1181	A4
15 Stud bolt KVN32–50	1.7709	1.7709	1.7709	A4
16 Belleville washer	50CrV4	50CrV4	50CrV4	1.4310
18 Disc	1.4401	1.4401	1.4401	1.4401
19 Serrated lock washer	spring steel	spring steel	spring steel	A2
21 Type plate	Al	Al	Al	Al

1) only DN 40 and DN 50

2) rilsanisiert

Suggested order specification
Shut off valve PN 40, PN 16, PN 6
 designed as straight-through piston valve, sealed off by 2 flexible valve rings – body made of cast iron, spheroidal cast iron, cast steel or stainless steel. Handwheel made of cast iron, piston made of special Niro-steel, overall length to EN 558-1 GR1, flanges drilled to EN 1092-1 resp. EN1092-2.
 Make: KLINGER
 Type: KVN VI KX for DN 10–50

Ordering example:
KVN 10-VIII KX, PN 40

Overall length in mm					approx. weight (kg)		
DN	L	H	Hub	A	PN 6 m.c. III	m.c. III/PN 16 m.c. VI/PN 40	PN 40 m.c. VIII/Xc
10	130	105	23	100	–	–	2,50
15	130	105	23	100	–	2,50	2,70
20	150	120	28	120	–	4,15	4,60
25	160	139	33	140	–	5,40	5,90
32	180	156	37	160	8,00	8,50	9,10
40	200	186	44	180	10,20	10,90	11,40
50	230	211	51	200	13,70	14,20	16,30

Piston valves KVN

Flange acc. to EN 1092-2 PN 16
Material: cast iron; valve ring KX-GT

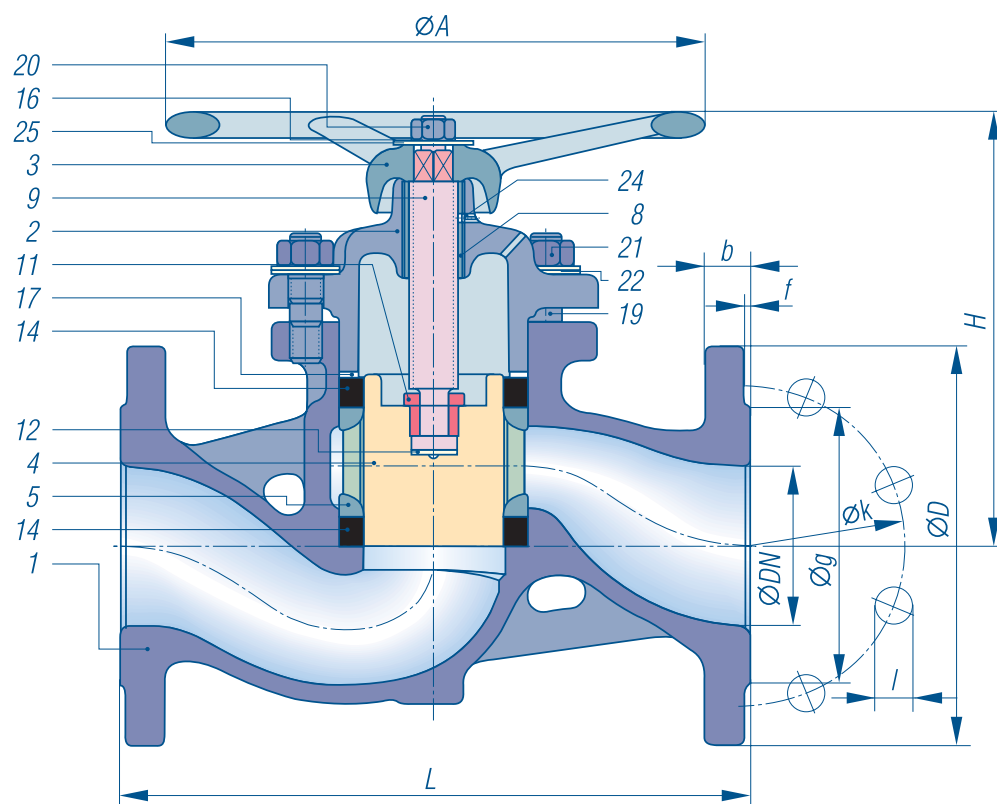

KVN 65 – 150

PN 16

material code III

PN 6

material code III

**overall length
acc. to EN 558-1
Grundreihe 1**

Pressure and temperatur
limits see page 15

Material code and flange
dimension see page 16

Part name	Material code III
1 Body	EN-GJL-250
2 Bonnet	EN-GJL-250
3 Handwheel	EN-GJL-200
4 Piston	1.4136
5 Lantern bush	EN-GJL-200
8 Threaded bush	Sint C11
9 Spindle	1.4021
11 Split nut	1.4401
12 Disc	1.4401
14 Upper valve ring	KX-GT
16 Serrated lock washer	spring steel
17 Washer	St37 / mat nickel
20 Handwheel nut	5
21 Bonnet nut	5
22 Belleville washer	50CrV4
24 Tension pin	spring steel
25 Type plate	Al

Suggested order specification

Shut off valves PN 16, PN 6

Designed as a straight-through piston valve, sealed off by 2 flexible valve rings – body and handwheel made of grey cast iron, piston made of special Niro-steel, overall length to EN 558-1 GR1, flanges drilled to EN 1092-2.

Make: KLINGER

Type: KVN III KX for DN 65 – 150

Ordering example:

KVN 65-III KX, PN 16

Overall length in mm					approx. weight (kg)	
DN	L	H	Hub	A	PN 6	PN 16
65	290	194,5	50	265	19,00	20,30
80	310	219	58	265	26,00	27,60
100	350	260	78	300	36,50	38,30
125	400	303	86	400	52,20	55,00
150	480	331	98	400	80,00	85,00



Piston valves KVNB

Flange acc. to EN 1092-2 PN, 16
Material: cast iron; valve ring KX-GT

KVNB 65 – 200

PN 16

material code III

overall length
acc. to EN 558-1
Grundreihe 1

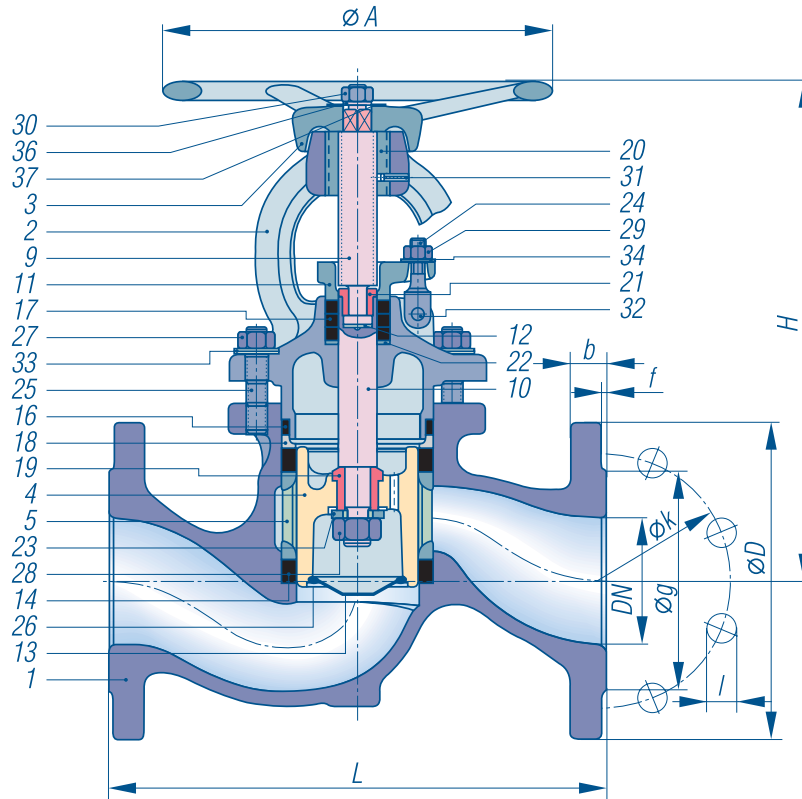

Pressure and temperatur
limits see page 15
Material code and flange
dimension see page 16

Suggested order specification Shut-off valve PN 16

Designed as straight-through piston valve, backseat relieved, sealed off by 3 flexible valve rings, stuffing box self retightening by means of bellville washer. Body and handwheel made of cast iron, piston made of special niro-steel. Overall length acc. to EN 558-1 GR1, flange drilled acc. to EN 1092-2 Make: KLINGER

Type: KVNB III KX for DN 65–200

Ordering example: KVNB 65-III KX, PN 16

PN 16					
Overall length in mm					approx. weight (kg)
DN	L	H	Hub	A	
65	290	194,5	50	265	24,0
80	310	219	58	265	30,5
100	350	260	78	300	46,5
125	400	303	86	400	69,0
150	480	331	98	400	85,0
200	600	561	118	400	157,5

Part name	Material code
1 Body	EN-GJL-250
2 Bonnet	EN-GJL 250
3 Handwheel	EN-GJL-200
4 Piston	1.4086
5 Lantern bush	EN-GJL-200
9 Spindle	1.4021
10 Piston shaft	1.4104
11 Gland retainer	EN-JS 1030
12 Disc	1.4401
13 Piston nose cone	1.4401
14 Upper valve ring	KX-GT
16 OT-valve ring	Graphit-L
17 Stuffingbox ring	KX-GT
18 Thrust piece	EN-GJL-200
19 Back seat	1.4104
20 Threaded bush	Sint C11 spec.
21 Split nut	1.4401
22 Washer	St 37 gal
23 Disc	1.4401
24 Swing bolt	5.6
25 Stud bolt	5.6
26 Securing ring	1.4310K
27 Bonnet nut	5
28 Bonnet nut notched	5
29 Bonnet nut	5
30 Bonnet nut	5
31 Tension pin	spring steel
32 Notched parallel pin	6.8
33 Belleville washer	50CrV4
34 Belleville washer	50 CrV4
36 Serrated lock washer	spring steel
37 Type plate	Al

Piston valves KVN

Flange acc. to EN 1092-2, PN 16/40, spheroidal cast iron
flange acc. to EN 1092-1 PN 16/40, cast steel; valve ring KX-GT

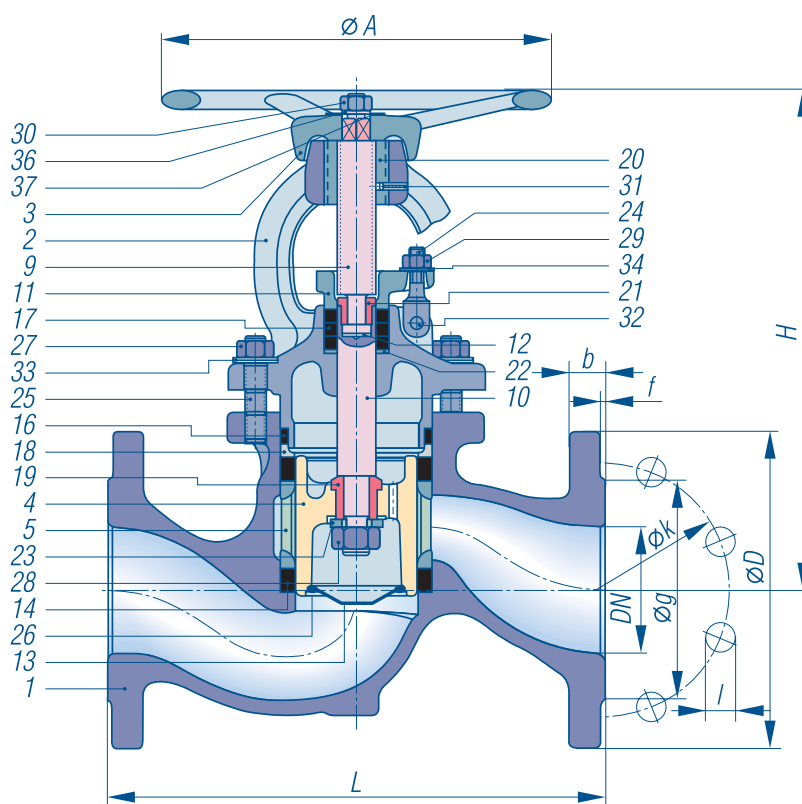

KVN 65 – 200

PN 40

DN 65–200

material code VI, VIII

PN 16

DN 65–200

material code VI

**overall length
acc. to EN 558-1
Grundreihe 1**

Pressure and temperatur
limits see page 15

Material code and flange
dimension see page 16

Suggested order specification Shut-off valves PN 40, PN 16

Designed as straight-through piston valves, beackseat-relieved, sealed off by 3 flexible valve rings – stuffing box self retightening by means of belleville washer, body made of spheroidal cast iron or cast steel. handwheel made of cast iron, piston made of special Niro-steel, overall length to EN 558-1 GR1, flanges drilled to EN1092-1 resp. EN1092-2

Make: KLINGER

Type: KVN VIII KX for DN 65–200

Ordering example:

KVN 65-VIII KX, PN 40

Part name	Material code		
	VI / PN 16	VI / PN 40	VIII
1 Body	EN-JS 1025	EN-JS 1025	1.0619
2 Bonnet	EN-JS 1025	EN-JS 1025	1.0619
3 Handwheel	EN-GJL-200	EN-GJL-200	EN-GJL-200
4 Piston	1.4086	1.4086	1.4086
5 Lantern bush	EN-GJL-200	EN-GJL-200	EN-GJL-200
9 Spindle	1.4021	1.4021	1.4021
10 Piston shaft	1.4104	1.4104	1.4104
11 Gland retainer	EN-JS 1030	EN-JS 1030	EN-JS 1030
12 Disc	1.4401	1.4401	1.4401
13 Piston nose cone	1.4401	1.4401	1.4401
14 Upper valve ring	KX-GT	KX-GT	KX-GT
16 OT-valve ring	Graphit-L	Graphit-L	Graphit-L
17 Stuffingbox ring	KX-GT	KX-GT	KX-GT
18 Thrust piece	1.0308	1.0308	1.0308
19 Back seat	1.4104	1.4104	1.4104
20 Threaded bush	Sint C11 special	Sint C11 special	Sint C11 special

Part name	Material code		
	VI / PN 16	VI / PN 40	VIII
21 Split nut	1.4401	1.4401	1.4401
22 Washer	St12.03	St12.03	St12.03
23 Disc	A4	A4	A4
24 Swing bolt	5.6	5.6	5.6
25 Stud bolt	1.7709	1.7709	1.7709
26 Securing ring	1.4310K	1.4310K	1.4310K
27 Bonnet nut	1.1181	1.1181	1.1181
28 Hexagon nut notched	5 black	5 black	5 black
29 Bonnet nut	1.1181	1.1181	1.1181
30 Bonnet nut	1.1181	1.1181	1.1181
31 Tension pin	spring steel	spring steel	spring steel
32 Notched parallel pin	6.8	6.8	6.8
33 Belleville washer	50CrV4	50CrV4	50CrV4
34 Belleville washer	50 CrV4	50 CrV4	50 CrV4
36 Serrated lock washer	spring steel	spring steel	spring steel
37 Type plate	Al	Al	Al

PN 40					
Overall length in mm					approx. weight (kg)
DN	L	H	Hub	A	
65	290	306	49	250	25,0
80	310	327	59	250	31,8
100	350	375	63	280	47,8
125	400	447	83	320	75,8
150	480	477	93	360	107,5
200	600	561	118	400	180,0

PN 16					
Overall length in mm					approx. weight (kg)
DN	L	H	Hub	A	
65	290	194,5	50	265	20,3
80	310	219	58	265	27,6
100	350	260	78	300	38,3
125	400	303	86	400	55,0
150	480	331	98	400	85,0
200	600	561	118	400	180,0



Piston valves KVMN

Female screwed ends with pipe thread acc. to ISO 228-1,
femal screwed ends with NPT-thread acc. to. ANSI B2.1
Materials: cast iron, cast steel, stainless steel; valve ring KX-GT

**KVMN 1/2"–2"
1/2"–2" NPT**

PN 63

DN 1/2"–2"

material code VIII, Xc

PN 16

DN 1/2"–2"

material code III

**Overall length to
DIN 3202-M9**

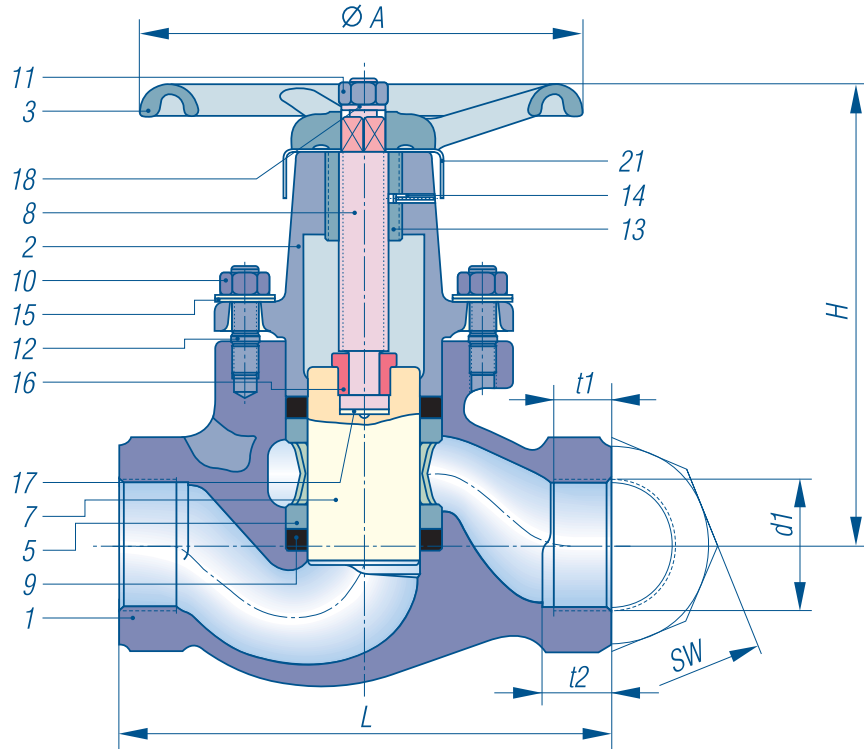

Pressure and temperatur
limits see page 15

Material code and flange
dimension see page 16

Suggested order specification Shut-off valve PN 63, PN 16

Designed as straight through piston
vlave, sealed-off by 2 flexible valve
rings – body made of cast iron, cast
steel or stainless steel. Handwheel
made of grey cast iron, piston made of
special Niro-steel. Overall length to DIN
3202-M9, bushes with pipe threads to
ISO 228-1, bushes with NPT threads to
ANSI B2.1.

Make: KLINGER

Type: KVMN VIII KX for DN 1/2"–2"
KVMN KX VIII for DN 1/2"–2" NPT

**Odering example:
KVMN 1/2"-III KX, PN 16**

Part name	Material code		
	III	VIII	Xc
1 Body	EN-GJL-250	1.0619	1.4581
2 Bonnet	EN-GJL-250	1.0460	1.4581
3 Handwheel	EN-GJL-200	EN-GJL-200	EN-GJL-200 rilansiert
5 Lantern bush	Sint C10	Sint C10	1.4408
7 Piston	1.4104	1.4104	1.4404
8 Spindle	1.4021	1.4021	1.4404
9 Upper valve ring	KX-GT	KX-GT	KX-GT
10 Bonnet nut	1.1181	1.1181	A4–70
11 Handwheel nut	1.1181	1.1181	A4–70
12 Stud bolt 1/2" – 1"	1.1181	1.1181	A4–70
Stud bolt 1 1/4" – 2"	1.7709	1.7709	A4–70
13 Threaded bush ¹⁾	–	Sint C11	Sint C11
14 Tension pin ¹⁾	–	spring steel	spring steel
15 Belleville washer	50CrV4	50CrV4	1.4310
16 Split nut	1.0715	1.0715	1.4571
17 Disc	1.4401	1.4401	1.4401
18 Serrated lock washer	spring steel	spring steel	A2
21 Type plate	Al	Al	Al

1) only DN 40 and DN 50

Overall length in mm					approx. weight (kg)	
DN	L	H	Hub	A	PN 16	PN 63
1/2"	100	105	23	100	1,40	1,50
3/4"	120	120	28	120	2,35	2,45
1"	135	138	33	140	3,50	3,60
1 1/4"	160	156	37	160	5,70	5,90
1 1/2"	185	186	44	180	8,10	8,50
2"	220	211	51	200	11,00	11,50

PN 16, PN 63							
DN	DIN Anschlussmuffen				NPT Anschlussmuffen		
	d1	t1	t2	SW	d1	t1	
1/2"	R½	15,5	19,5	36	1/2"–14 NPT	13,5	19,5
3/4"	R¾	16,0	20,0	41	3/4"–14 NPT	14,0	20,0
1"	R1"	17,0	22,0	50	1"–11 1/2 NPT	17,0	24,0
1 1/4"	R1 ¼	19,0	25,0	65	1 1/4"–11 1/2 NPT	17,5	24,5
1 1/2"	R1 ½	19,0	24,0	75	1 1/2"–11 1/2 NPT	17,5	24,5
2"	R2"	26,0	31,0	90	2"–11 1/2 NPT	18,0	25,0

Piston valves KVSN

Socket weld ends acc. to EN 12 760
Material: cast steel; valve ring KX-GT

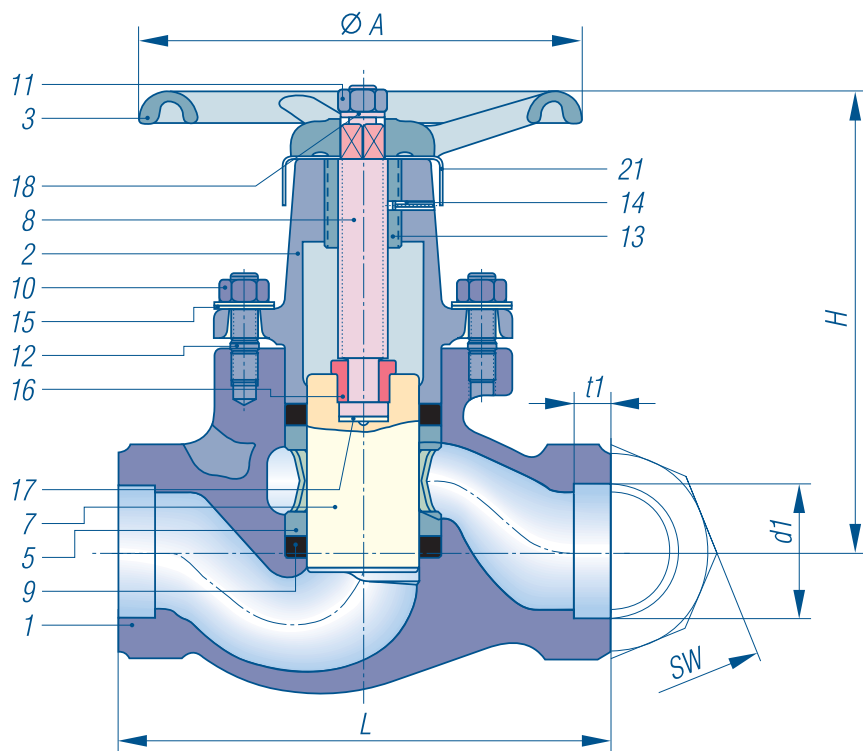

KVSN 1/2"–2"

PN 63

DN 1/2"–2"

material code VIII

Overall length acc. to
DIN 3202-M9

Pressure and temperatur
limits see page 15

Material code and flange
dimension see page 16

DN	Connection dimensions in mm		
	d1	t1	SW
1/2"	21,80	10	36
3/4"	27,10	13	41
1"	33,80	13	50
1 1/4"	42,60	13	65
1 1/2"	48,70	13	75
2"	61,20	16	90

Part name	Material code VIII
1 Body	1.0619
2 Bonnet	1.0460
3 Handwheel	EN-GJL-200
5 Lantern bush	Sint C10
7 Piston	1.4104
8 Spindle	1.4021
9 Upper valve ring	KX-GT
10 Bonnet nut	1.1181
11 Handwheel nut	1.1181
12 Stud bolt 1/2" – 1"	1.1181
Stud bolt 1 1/4" – 2"	1.7709
13 Threaded bush ¹⁾	Sint C11
14 Tension pin ¹⁾	spring steel
15 Belleville washer	50CrV4
16 Split nut	1.0715
17 Disc	1.4401
18 Serrated lock washer	spring steel
21 Type plate	Al

1) only DN 40 and DN 50

Suggested order specification Shut-off valve PN 63

Designed as straight-through piston valve, sealed-off by 2 flexible valve rings, body made of cast steel and handwheel made of cast iron, piston made of special Niro-steel, overall length to DIN 3202-M9.

Socket weld ends to EN 12 760

Make: KLINGER

Type: KVSN VIII KX for DN 1/2"–2"

Ordering example:

KVSN 1/2"-VIII KX, PN 63

KVSN 1/2" – 2"

Overall length in mm					weight (kg)
DN	L	H	Hub	A	
1/2"	100	105	23	100	1,50
3/4"	120	120	28	120	2,45
1"	135	138	33	140	3,60
1 1/4"	160	156	37	160	5,90
1 1/2"	185	186	44	180	8,50
2"	220	211	51	200	11,50



Piston valves KVSN

butt weld ends acc. to EN 12 627
Material: cast steel; valve ring KX-GT

KVSN 15 – 50

PN 63

DN 15–50

material code VIII

Overall length acc.
to Klinger-standard

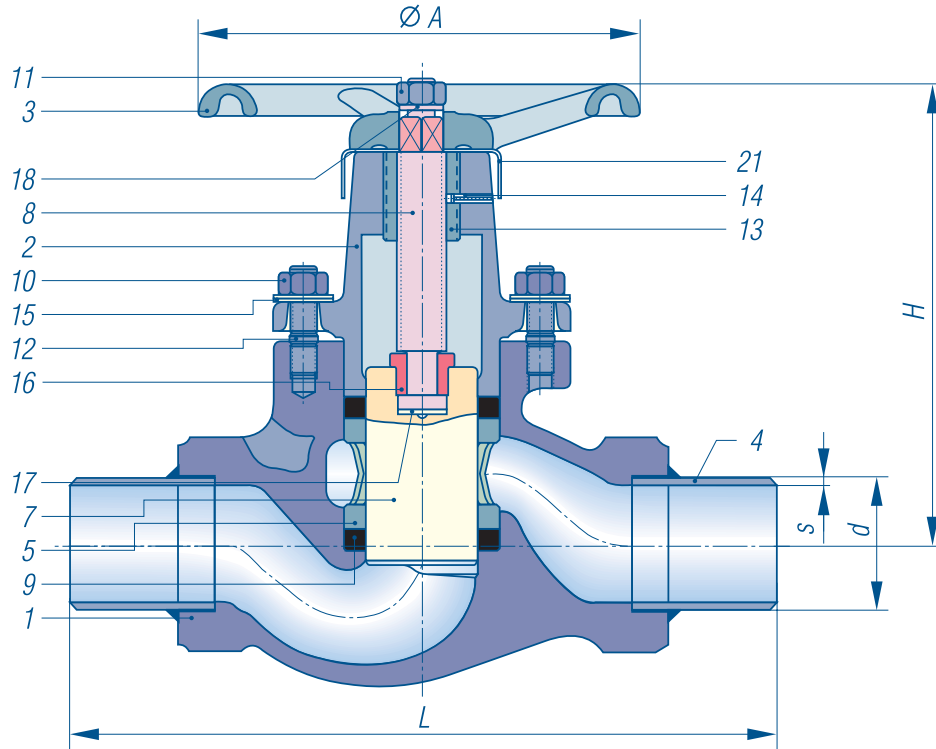

Pressure and temperatur
limits see page 15
Material code and flange
dimension see page 16

Connection dimensions in mm		
DN	d	s
15	21,3	3,25
20	26,9	3,25
25	33,7	4,00
32	42,4	4,00
40	48,3	4,00
50	60,3	4,50

Part name	Material code VIII
1 Body	1.0619
2 Bonnet	1.0460
3 Handwheel	EN-GJL-200
4 Pipe thread	1.0305
5 Lantern bush	Sint C10
7 Piston	1.4104
8 Spindle	1.4021
9 Upper valve ring	KX-GT
10 Bonnet nut	1.1181
11 Handwheel nut	1.1181
12 Stud bolt 15–25	1.1181
Stud bolt 32–50	1.7709
13 Threaded bush ¹⁾	Sint C11
14 Tension pin ¹⁾	spring steel
15 Belleville washer	50CrV4
16 Split nut	1.0715
17 Disc	1.4401
18 Serrated lock washer	spring steel
21 Type plate	Al

¹⁾ only DN 40 and DN 50

Suggested order specification Shut-off valves PN 63

Designed as a straight-through piston valve, sealed off by 2 flexible valve rings, body made of cast steel, handwheel made of cast iron, piston made of special Ni-ro-steel, butt weld ends acc. to EN 12 627

Make: KLINGER

Type: KVSN VIII KX for DN 15–50

Ordering example:
KVSN 15-VIII KX, PN 63

DN	Overall length in mm				approx. weight (kg)
	L	H	Hub	A	
15	145	105	23	100	1,70
20	170	120	28	120	2,55
25	200	138	33	140	3,80
32	230	156	37	160	6,20
40	270	186	44	180	8,90
50	320	211	51	200	12,20

Pressure-/temperature diagrams

Economical consideration
Application limitations

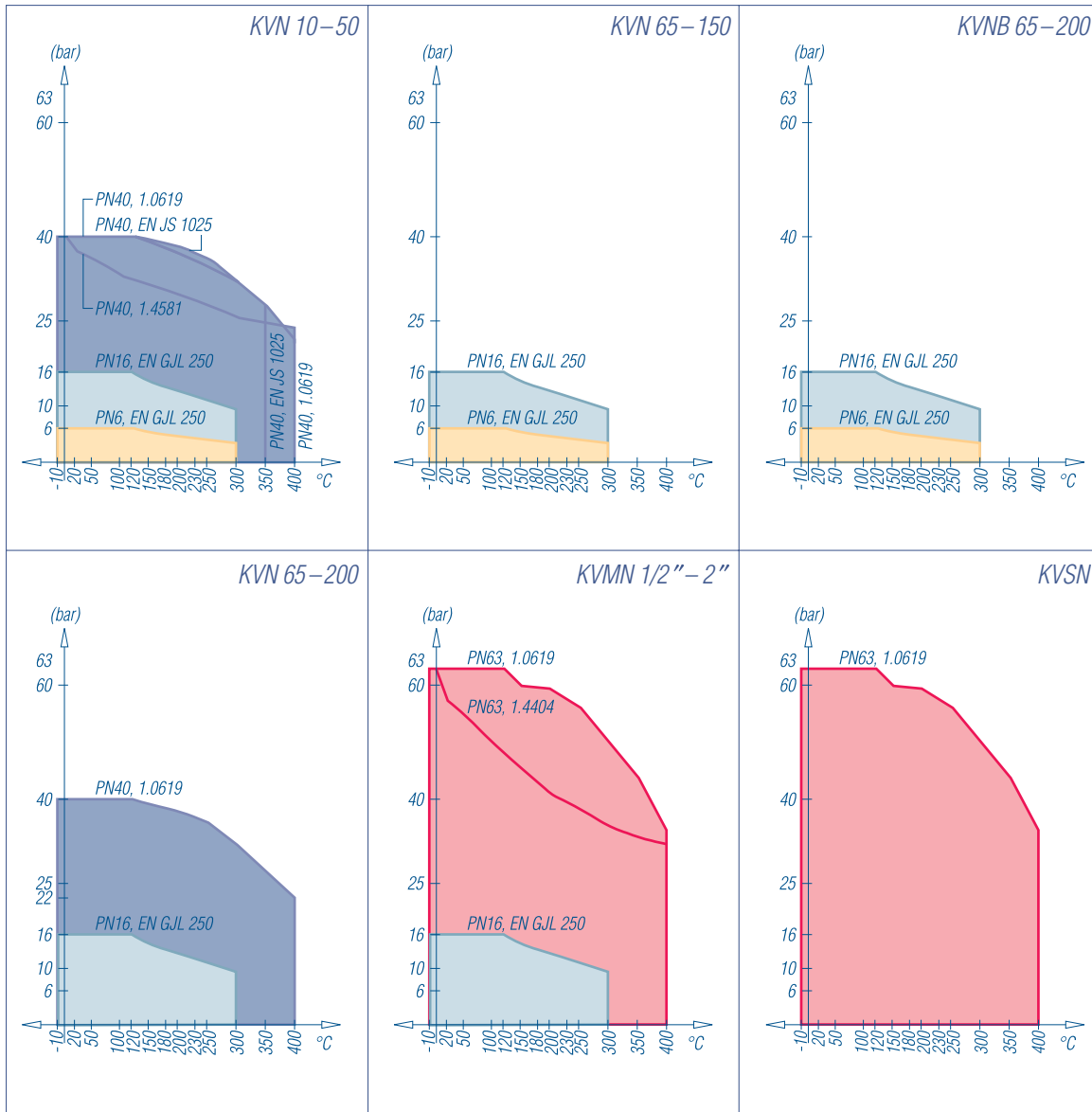

Pressure-/temperature diagrams

This pressure-/temperature diagram helps you to choose the most economical of the KLINGER piston valves KVN.



Connection dimensions in mm

PN 6 cast iron							
DN	D	b	g	f	number of holes	l	k
32	120	14	69	3	4	14	90
40	130	14	78	3	4	14	100
50	140	14	88	3	4	14	110
65	160	14	108	3	4	14	130
80	190	19	124	3	4	19	150
100	210	19	144	3	4	19	170
125	240	19	174	3	8	19	200
150	265	19	199	3	8	19	225

PN 16 cast iron, spheroidal cast iron							
DN	D	b	g	f	number of holes	l	k
15	95	16	46	2	4	14	65
20	105	18	56	2	4	14	75
25	115	18	65	3	4	14	85
32	140	18	76	3	4	19	100
40	150	18	84	3	4	19	110
50	165	18	99	3	4	19	125
65	185	20	118	3	4	19	145
80	200	22	132	3	8	19	160
100	220	24	156	3	8	19	180
125	250	26	184	3	8	19	210
150	285	26	211	3	8	23	240
200	340	30	266	3	12	23	295

PN 40 spheroidal cast iron							
DN	D	b	g	f	number of holes	l	k
15	95	16	46	2	4	14	65
20	105	18	56	2	4	14	75
25	115	18	65	3	4	14	85
32	140	18	76	3	4	19	100
40	150	19	84	3	4	19	110
50	165	19	99	3	4	19	125
65	185	19	118	3	8	19	145
80	200	19	132	3	8	19	160
100	235	19	156	3	8	23	190
125	270	23,5	184	3	8	28	220
150	300	26	211	3	8	28	250
200	375	30	284	3	12	31	320

PN 40 cast steel, stainless steel							
DN	D	b	g	f	number of holes	l	k
10	90	16	40	2	4	14	60
15	95	16	45	2	4	14	65
20	105	18	58	2	4	14	75
25	115	18	68	2	4	14	85
32	140	18	78	2	4	18	100
40	150	18	88	2	4	18	110
50	165	20	102	2	4	18	125

PN 40 cast steel							
DN	D	b	g	f	number of holes	l	k
65	185	22	122	2	8	18	145
80	200	24	138	2	8	18	160
100	235	24	162	2	8	22	190
125	270	26	188	2	8	26	220

Material code (m.c.)

m.c.	Body	Bonnet	internal parts	colour of body
III	cast iron	cast iron	without copper alloy parts	black phosphated
VI	spheroidal cast iron	spheroidal cast iron	without copper alloy parts	black phosphated
VIII	cast steel	cast steel	without copper alloy parts	black phosphated
Xc	stainless steel	stainless steel	stainless steel	polished, pickled

Primary criterion for the material code number is the basic material of the body and bonnet.

Flow coefficient and zeta-values

Type KVN													
DN	10	15	20	25	32	40	50	65	80	100	125	150	200
k_v	2	4,5	8	12,5	20,5	32	50	69	104	163	233	335	582
ζ	4	4	4	4	4	4	4	6	6	6	7,2	7,2	7,2

$KV =$ Flow coefficient (m^3/h)
 $\zeta =$ Zeta-value

The values shown in the table have an accuracy of $\pm 10\%$ and apply to water at a temperature of $20\text{ }^\circ\text{C}$ and a density of approx. 1000 kg/m^3 .

Graphs and exact flow calculations for all KLINGER valves are available at request

Technical data

Application limitations with KX-GT

Service category	Permissible working pressure (bar) at pressure rating					Lowest permissible working temperature in °C KVN KX			
	63	40	25	16	10	III	VI	VIII	Xc
I	63								
		40							
			25				-10	-10	-10 ³⁾
				16		-10			
					10				
II	48								
		30							
			19				-60 ²⁾	-60 ^{1) 2)}	-60 ³⁾
				12		-10			
					10				
III	16								
		10							
			6				-60 ^{1) 2)}	-60 ^{1) 2)}	-85 ³⁾
				4		-10			
					2,5				

- 1) with A4 screws
- 2) with lantern made of stainless steel
- 3) Material 1.4408 is admitted up to -196 °C at request

Belleville washers, stud bolts

DN	Body – Bonnet				Bonnet – Gland retainer			
	belleville washer		stud bolts		belleville washer		stud bolts	
	Dimension	piece	Dimension	piece	Dimension	piece	Dimension	piece
10/15	20× 10,2× 1	4	M 10× 30	2				
20	20× 10,2× 1	6	M 10× 30	3				
25	20× 10,2× 1	8	M 10× 30	4				
32	28× 12,2× 1,5	8	M 12× 35	4				
40	28× 12,2× 1,5	8	M 12× 35	4				
50	28× 12,2× 1,5	8	M 12× 35	4				
65	34× 16,3× 2	8	M 16× 55	4	20× 10,2× 1	4	M 10× 50	2
80	34× 16,3× 2	12	M 16× 55	6	20× 10,2× 1	4	M 10× 50	2
100	34× 16,3× 2	16	M 16× 60	8	20× 10,2× 1	4	M 10× 50	2
125	40× 20,4× 2,25	12	M 20× 70	6	20× 10,2× 1	4	M 10× 50	2
150	40× 20,4× 2,25	16	M 20× 70	8	20× 10,2× 1	4	M 10× 50	2
200	50× 25,4× 2,5	16	M 24× 75	8	20× 10,2× 1	4	M 10× 50	2

Dimensions of valve rings and stuffing box rings

DN 10–50 m.c. III, VI, VIII, Xc				
Type	item	outside diameter	inside diameter	H
KVN KX 10	2 valve rings	23,5	15	8.0
KVN KX 15	2 valve rings	23,5	15	8.0
KVN KX 20	2 valve rings	30	20	9.3
KVN KX 25	2 valve rings	38	25	10.6
KVN KX 32	2 valve rings	45	30	14.6
KVN KX 40	2 valve rings	58	40	14.6
KVN KX 50	2 valve rings	70	50	16.0

DN 65–150 m.c. III				
Type	item	outside diameter	inside diameter	H
KVN KX 65	2 valve rings	82	60	13.3
KVN KX 80	2 valve rings	94	70	14.6
KVN KX 100	2 valve rings	112	90	14.6
KVN KX 125	2 valve rings	135	110	16.0
KVN KX 150	2 valve rings	155	130	17.3

DN 65–200 m.c. III (KVN B), VI, VIII				
Type	item	outside diameter	inside diameter	H
KVN KX 65	2 valve rings	82	60	13.3
	1 bonnet valve ring	82	69	10.0
	3 stuffing box rings	36	24	8.0
KVN KX 80	2 valve rings	94	70	14.6
	1 bonnet valve ring	94	80	10.0
	3 stuffing box rings	36	24	8.0
KVN KX 100	2 valve rings	112	90	14.6
	1 bonnet valve ring	112	100	11.0
	3 stuffing box rings	46	30	10.0
KVN KX 125	2 valve rings	135	110	16.0
	1 bonnet valve ring	135	121	13.0
	3 stuffing box rings	46	30	10.0
KVN KX 150	2 valve rings	155	130	17.3
	1 bonnet valve ring	155	141	13.0
	3 stuffing box rings	46	30	10.0
KVN KX 200	2 valve rings	200	170	18.6
	1 bonnet valve ring	200	184	15.0
	3 stuffing box rings	46	30	10.0



Special designs

KVN with heating jacket
KVN Fire-safe

KVN with heating jacket

All KLINGER piston valves KVN can be provided with heating jacket.

Overall- / connection dimensions and application range, see the appropriate product pages.

KLINGER piston valves with heating jacket are designed for the use with viscous media or media which solidify when cold.

The jacket is made of stainless steel 1.4541 and may be used with all heating fluids for which steel piping is suitable. Two heating connections and a drain connection are provided on the heating jacket. The max. heating fluid pressure is 6 bar. Since considerable condensation may be expected in the heating jacket when steam heating is used, it is advisable to connect a steam trap to the drain connection of the jacket. Max. pressure of heating medium 6 bar.

Pressure rating of the heating jacket: max. 6 bar

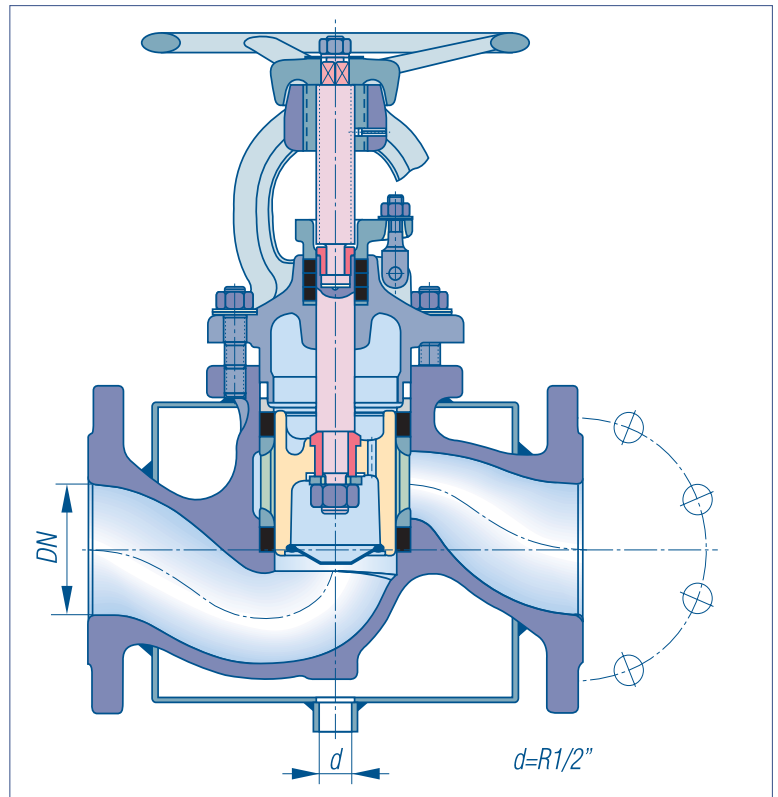

KVN Fire-safe tested acc. to API 6FA

The Fire-safe test was conducted by TÜV in Austria, acc. to API Standard 6FA and ISO 10497.

The Fire-safe-type KVN requires a special type of sealing elements across the port which the KVN is supplied with and can also be retrofitted without problems. This is the advantage of the KLINGER-modular systems.



Regulation piston valves

Regulation piston valves

Klinger piston valves are excellent suited for controlling applications. From size DN 10 up to 50 the regulation of flow is done with a regulating piston. A regulating lantern bush is used for regulation of piston valves with nominal diameter bigger than DN 65. Klinger regulation piston valves are designed for a linear regulation characteristics. The data sheet could be send on request.

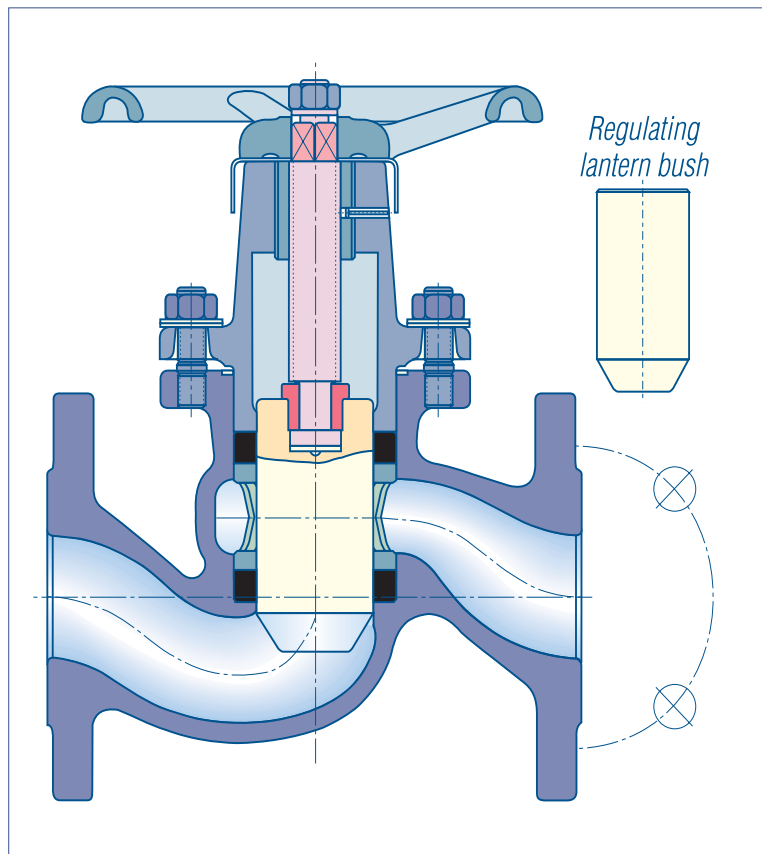
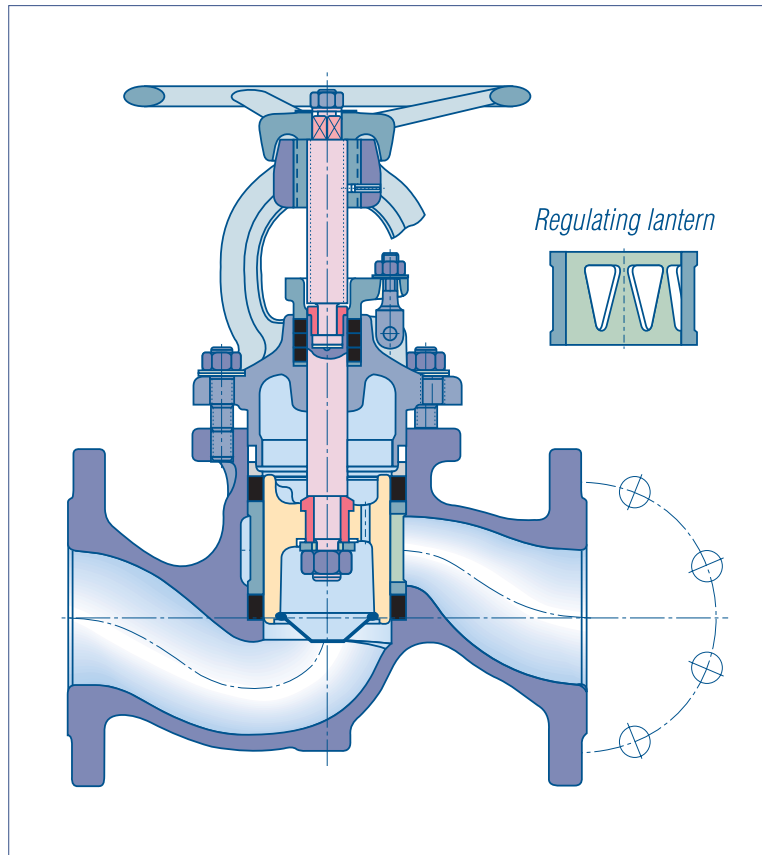



Special designs

KVN KX1 for TA-Luft and EPA applications



KVN KX-1 for TA-Luft and EPA applications

The standard KX-GT valve ring of this special design is equipped with additional Klingerflon gaskets. These additional rings are joined to the upper valve ring resp. the stuffing box. This system guarantees lowest leakage rates (2 ppm !) and meets the TA-Luft and EPA-requirements even better than conventional sealings.

All other parts of the valves are as in the standard design and the according specifications.

Media in the temperature range from $-196\text{ }^{\circ}\text{C}$ to $+300\text{ }^{\circ}\text{C}$ and pressures up to 63 bar can be reliably sealed with the KLINGER piston valve KVN with KX-1 sealing system.

All KLINGER piston valves already in service can easily be equipped with the KX-1 system without disassembly.

TA-Luft = Technische Anleitung Luft (technical guidelines air) Germany
EPA = Environmental Protection Agency USA

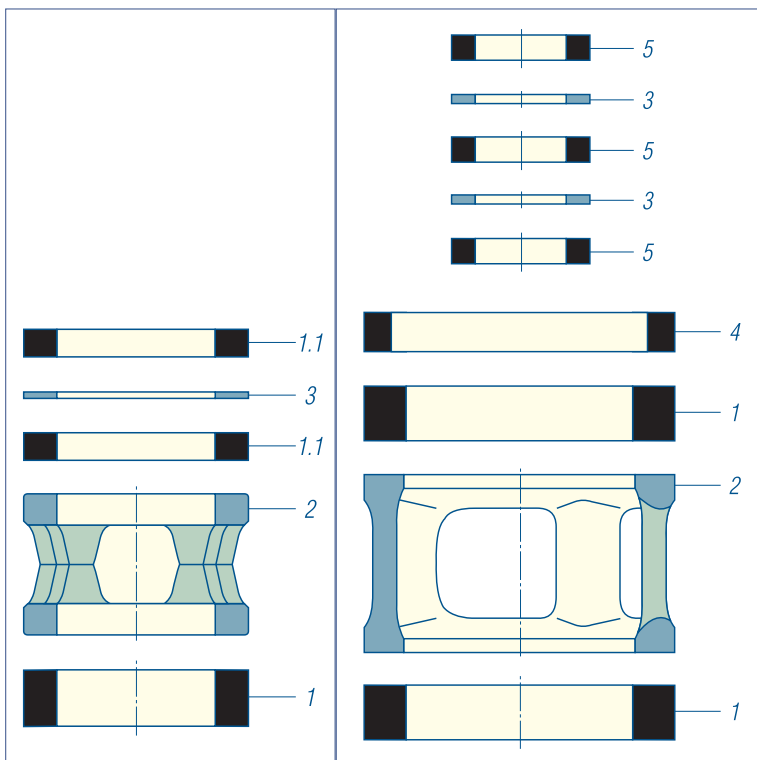

KVN 10–50

KVN 65–200

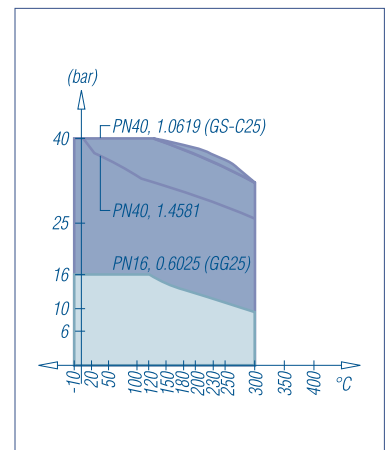

Part name	Material
1 Valve ring	KX-GT
1.1 Valve ring	KX-GT
2 Lantern bush	Sint C10 / EN-GJL-200
3 Gasket	K-Flon
4 OT-Valve ring	Graphit-L
5 Stuffingbox ring	KX-GT

KVN certification

Manufacturer- and type approvals

No.	Tests and approvals	Testing institute	Certificate resp. registration Nr.
1	Quality system ISO 9001	TÜV CERT Austria	20 100 0918
2	Manufacturer approval acc. to AD-Merkblatt HPO and TRB 801 No. 45	TÜV Bayern	21878
3	Welding approval acc. to DIN EN 729-2	TÜV Süddeutschland	21878
4	Welding approval acc. to OENORM EN 729-2	TÜV Austria	PZ/00/S/091/HVK
5	Manufacturer approval for welding acc. to OENORM M 7812 Part name 1	TÜV Austria	V 1225/Sei/85
6	Approval acc. to Pressure Equipment Directive 97/23/EG/DGVO 426/99	TÜV Austria	Q02/00
7	Type approval for KVN 10-50 acc. to VdTÜV 1065	TÜV Bayern	TÜV.AR.086-96
8	Type approval for KVN 10-50 for tankers (RID/ADR+TRT)	TÜV Bayern	TÜ.AGG.252-95
9	Fire-safe-test KVN 2" Class 300 acc. to API 6F	Southwest Research Institute / USA	Test No. 6-298
10	Fire-safe-test KVN 50 PN 40 acc. to API 6F	TÜV Austria	V 371/MK/WR
11	Fire-safe-test KVN 100 PN 40 acc. to API 6F	TÜV Austria	V 1798/SEI/HA
12	Release for oxygen service for KVN 10-200	BAM Berlin	Tgb.Nr. 6494/96 IV
13	TA-Luft-tests with KVN 50 PN 40 with KX-1/rings	TÜV Hessen	W 8000/2
14	TA-Luft-tests for KVN 100 PN 40 with KX-1/rings	TÜV Austria	WP 1430/GÖ/FUK
15	TA-Luft-tests for KVN 50 PN 40 with TFM 1600/rings	TÜV Austria	WP 919/MK/BE
16	Registrations of KVN in Canada TSSA Cabada	TSSA Cabada	CRN OC...
17	EN ISO 15848-1 (VDI 2440) tests for KVN 25 PN 40 with KX1-SLS rings	TÜV Austria	WP2337/MK/BE-E



Leakage rates

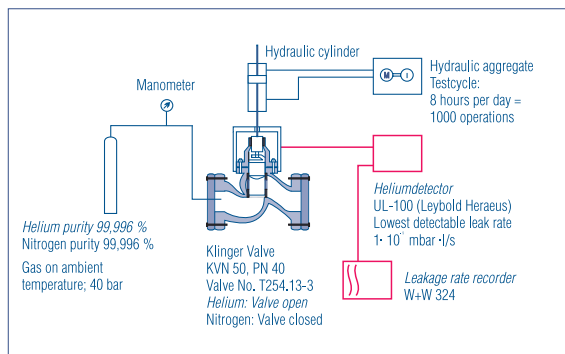

KVN KX1-GT 50.000 cycle test



Table of chemical resistance

All given **recommendations** are intended to help in selecting suitable materials and valve types. No guarantee can be given since performance and service life of the products depend on a series of factors on which the manufacturer has no influence. Special regulations must be observed. **Please contact us in case of doubt.** Solid media listed in the table are to be understood as aqueous solutions or suspensions.

EN-GJL250 cast iron to EN 1561

EN-JS 1025 spheroidal cast iron to EN 1563

1.0619 mild cast steel acc. to EN 10213

1.4581 stabilised chrome-nickel-molybdenum steel acc. to EN 10213

Sealing ring materials:

KX GT special sealing based on graphite

TFM-1600 special sealing PTFE-based

Explanation of symbols

for metallic materials:

0 = practically resistant, loss in weight less than 2,4 g/m²/day

1 = fairly resistant, loss in weight 2,4–24 g/m²/day

2 = low resistance, loss in weight 24–72 g/m²/day

3 = non-resistant, loss in weight more than 72 g/m²/day

– = not tested or not customary

for sealing materials:

• = suitable

– = not suitable

Abbreviations:

Bp. = boiling point

satd. sol. = saturated solution

hyd.sol. = hydrous solution

conc. = concentrated

Fluid	Chemical formula	Concentration and temperature		Materials for seals		Metallic materials			Material code
		%	°C	KX-GT	TFM-1600	EN-JS 1025 EN-GJL 250	1.0619	1.4581	
Aceton	CH ₃ COCH ₃		20	•	•	0	0	0	all
Acetylen	C ₂ H ₂			•	•	0	0	0	III, VIII, X, Xc
Air, dry				•	•	0	0	0	all
Alum	KAl(SO ₄) ₂	10	20	•	•	–	–	0	X, Xc
Alum	KAl(SO ₄) ₂	10	100	•	•	–	–	0	X, Xc
Aluminium acetate	(CH ₃ COO) ₃ Al			•	•	3	3	0	X, Xc
Aluminium chlorate	Al(ClO ₃) ₃			•	•	–	–	0	X, Xc
Aluminium ethylate	Al(OC ₂ H ₅) ₂			•	•	0	0	0	all
Aluminium fluoride	AlF ₃			•	•	0	0	3	III, VIII
Aluminium oxyde	Al ₂ O ₃			•	•	0	0	0	all
Ammonium hydroxyde	NH ₄ OH	10	20	•	•	0	0	0	III, VIII, X, Xc
Ammonium hydroxyde	NH ₄ OH	10	100	•	•	0	0	0	III, VIII, X, Xc
Ammonium bicarbonate	(NH ₄)HCO ₃			•	•	0	0	0	III, VIII, X, Xc
Ammonium carbonate	(NH ₄) ₂ CO ₃		Kp	•	•	2	2	0	X, Xc
Ammonium chloride	NH ₄ Cl	5	20	•	•	1	1	0	all
Ammonium chloride	NH ₄ Cl	10	20	•	•	1	1	0	all
Ammonium chloride	NH ₄ Cl	10	100	•	•	3	3	0	X, Xc
Ammonium chloride	NH ₄ Cl	50	20	•	•	1	1	0	all ¹⁾
Ammonium diphosphate	(NH ₄) ₂ HPO ₄			•	•	1	1	0	III, VIII, X, Xc
Ammonium nitrate	NH ₄ NO ₃		20	•	•	2	2	0	X, Xc
Ammonium sulphate	(NH ₄) ₂ SO ₄		20	•	•	3	3	0	X, Xc
Aniline	C ₆ H ₅ NH ₂			•	•	0	0	0	all
Arsenic acid	H ₃ AsO ₄			•	•	2	2	0	X, Xc
Asphalt (tar)				•	•	–	–	0	X, Xc
Beer				•	•	3	3	0	X, Xc
Benzine				•	•	0	0	0	all
Benzene	C ₆ H ₆			•	•	0	0	0	all
Bleaching liquor (chloride of lime)				•	•	–	–	1	X, Xc
Borax	Na ₂ B ₄ O ₇ 10 H ₂ O			•	•	–	–	0	X, Xc

Fluid	Chemical formula	Concentration and temperature		Materials for seals		Metallic materials			Material code
		%	°C	KX-GT	TFM-1600	EN-15 1025 EN-6LL 250	1.0619	1.4681	
Boric acid	H ₃ BO ₃	4	20	•	•	2	2	0	X, Xc
Boric acid	H ₃ BO ₃	4	100	•	•	2	2	0	X, Xc
Boric acid	H ₃ BO ₃	100	100	•	•	2	2	0	X, Xc
Butane	C ₄ H ₁₀			•	•	0	0	0	all
Buttermilk			20	•	•	–	–	0	X, Xc
Butyl acetate	CH ₃ COOC ₄ H ₉			•	•	0	0	0	all
Butyl alcohol	C ₄ H ₉ OH			•	•	0	0	0	all
Calcium bisulphite	Ca(HS O ₃) ₂		20	–	•	2	3	0	X, Xc
Calcium bisulphite	Ca(HS O ₃) ₂		200	•	•	2	3	0	X, Xc
Calcium chloride	CaCl ₂		20	•	•	1	1	0	X, Xc
Calcium chloride	CaCl ₂		100	•	•	2	2	1	X, Xc
Calcium hydroxide (milk of lime)	Ca(OH) ₂			•	•	0	0	0	all
Calcium hypochlorite	Ca(ClO) ₂			–	•	2	2	1	X, Xc
Calcium sulphate	CaSO ₄			•	•	0	0	0	all
Carbon dioxide, dry	CO ₂	to	150	•	•	0	0	0	all
Carbon dioxide, dry	CO ₂		400	•	•	0	0	0	VII, X, Xc
Carbon disulphide	CS ₂		20	•	•	0	0	0	III, VIII, X, Xc
Carbon tetrachloride	CCl ₄			•	•	1	1	0	all
Chlor sulphonic acid	HOSO ₂ Cl		Kp	•	•	1	1	3	all
Chloroform	CHCl ₃			•	•	0	0	0	all
Chloroform	CHCl ₃		20	•	•	0	0	0	all
Chromic acid	H ₂ CroO ₄	10	20	•	•	1	0	0	III, VIII, X, Xc
Chromic acid	H ₂ CroO ₄	10	Kp	•	•	–	–	0	X, Xc
Chromic acid	H ₂ CroO ₄	50	20	•	•	0	0	0	III, VIII, X, Xc
Citric acid	(CH ₂ COOH) ₂ C(OH)COOH		20	•	•	3	3	0	X, Xc
Citric acid	CH ₂ COOH) ₂ C(OH)COOH		Kp	•	•	3	3	0	X, Xc
Clophen T 64				•	•	0	0	0	all
Copper acetate wat. sol.	(CH ₃ COO) ₂ Cu		20	•	•	0	0	0	all
Copper acetate wat. sol.	(CH ₃ COO) ₂ Cu		Kp	•	•	2	2	0	X, Xc
Copper sulphate	CuSO ₄		20	•	•	3	2	0	X, Xc
Copper sulphate	CuSO ₄		Kp	•	•	3	2	0	X, Xc
Diazotation bath, (weakly acid)			20	•	•	2	2	1	X, Xc
Diazotation bath, (weakly acid)			80	•	•	2	2	1	X, Xc
Diesel oil			20	•	•	0	0	0	all
Diphyl				•	•	0	0	0	all ³⁾
Dowtherm A				•	•	0	0	0	all ³⁾
Dye liquor, alkaline or neutral			20	•	•	–	–	0	X, Xc
Dye liquor, alkaline or neutral			Kp	•	•	–	–	0	X, Xc
Dye liquor, organic acid			20	•	•	–	–	0	X, Xc
Dye liquor, organic acid			Kp	•	•	–	–	0	X, Xc
Dye liquor, strongly sulphuric acid	H ₂ SO ₄ above 0,3%		20	•	•	–	–	0	X, Xc
Dye liquor, strongly sulphuric acid	H ₂ SO ₄ above 0,3%		Kp	•	•	–	–	1	X, Xc
Dye liquor, weakly sulphuric acid	H ₂ SO ₄ under 0,3%		Kp	•	•	–	–	0	X, Xc
Ethane	C ₂ H ₆			•	•	0	0	0	all
Ethanol	C ₂ H ₅ OH			•	•	0	0	0	all
Ethyl acetate	CH ₃ COOC ₂ H ₅		Kp	•	•	0	0	0	all
Ethyl ether	C ₂ H ₅ OC ₂ H ₅			–	•	1	1	0	all



Fluid	Chemical formula	Concentration and temperature		Materials for seals		Metallic materials			Material code
		%	°C	KX-GT	TFM-1600	EN-1025 EN-6LL 250	1.0619	1.4581	
Ethylen chloride (Dichlorethan)	$(CH_2Cl)_2$	20		•	•	0	0	0	all
Ethylene	C_2H_4			–	•	0	0	0	all ¹⁾
Fatty acids from C_6				•	•	1	1	0	all
Formaldehyde	HCHO	40	20	•	•	3	3	0	X, Xc
Formaldehyde	HCHO	40	Kp	•	•	3	3	0	X, Xc
Formic acid	HCOOH	10	20	•	•	3	3	0	X, Xc
Formic acid	HCOOH	10	100	•	•	3	3	1	X, Xc
Formic acid	HCOOH	100	20	•	•	3	3	0	X, Xc
Formic acid	HCOOH	100	100	•	•	3	3	1	X, Xc
Freon				•	•	0	0	0	all
Glacial acetic acid	CH_3COOH		20	•	•	2	2	0	X, Xc
Glacial acetic acid	CH_3COOH	10	20	•	•	2	2	0	X, Xc
Glacial acetic acid	CH_3COOH	10	Kp	•	•	2	2	0	X, Xc
Glacial acetic acid	CH_3COOH	50	20	•	•	3	2	0	X, Xc
Glacial acetic acid	CH_3COOH	50	Kp	•	•	3	2	1	X, Xc
Glacial acetic acid	CH_3COOH	80	20	•	•	3	2	1	X, Xc
Glacial acetic acid	CH_3COOH	80	Kp	•	•	3	2	1	X, Xc
Glycerine	$(CH_2OH)_2CHOH$		20	•	•	2	2	0	X, Xc
Glycerine	$(CH_2OH)_2CHOH$		100	•	•	2	2	0	X, Xc
Grape vinegar			20	•	•	–	–	0	X, Xc
Heat transfer oils				•	•	0	0	0	all ³⁾
Hydrochloric acid	HCl	0,2	20	•	•	3	3	0	X, Xc
Hydrochloric acid	HCl	0,2	50	•	•	3	3	1	X, Xc
Hydrochloric acid	HCl	1	20	•	•	3	3	1	X, Xc
Hydrochloric acid, dry	HCl		20	•	•	1	1	1	all
Hydrochloric acid, dry	HCl		100	•	•	1	1	2	all
Hydrogen	H_2			•	•	0	0	0	all ⁴⁾
Hydrogen peroxide	H_2O_2		20	•	•	3	3	0	X, Xc
Hydrogen peroxide	H_2O_2		50	–	•	3	3	0	X, Xc
Hydrogen sulphide, gas, dry	H_2S		20	•	•	–	–	0	X, Xc
Hydrogen sulphide, gas, wet	H_2S		20	•	•	–	–	0	X, Xc ¹⁾
Hydroxylamine sulphate	$(NH_2OH)H_2SO_4$	10	20	•	•	–	–	0	X, Xc
Hydroxylamine sulphate	$(NH_2OH)H_2SO_4$	10	Kp	•	•	–	–	0	X, Xc
Illuminating gas				•	•	0	0	0	all
Kreosote			20	–	•	–	–	0	X, Xc
Kreosote			Kp	–	•	–	–	0	X, Xc
Lead acetate (lead sugar)	$Pb(CH_3COO)_2$	100	Kp	•	•	3	3	2	X, Xc
Lead arsenate	$Pb(AsO_4)_2$			•	•	–	–	0	X, Xc
Linseed oil			20	•	•	–	–	0	X, Xc
Linseed oil			100	•	•	–	–	0	X, Xc
M. E. K (Butanone)	$CH_3COC_2H_5$		Kp	•	•	1	1	0	all
Manganous chloride	$MnCl_2$		20	•	•	2	2	0	X, Xc
Manganous chloride	$MnCl_2$		Kp	•	•	2	2	0	X, Xc
Magnesium sulphate	$MgSO_4$		20	•	•	1	1	0	all
Magnesium sulphate	$MgSO_4$		Kp	•	•	1	1	0	all
Mercury	Hg		20	•	•	1	1	0	III, VIII, X, Xc
Mercury (II) chloride	$HgCl_2$		20	•	•	3	3	0	X, Xc
Mercury (II) nitrate	$Hg(NO_3)_2$		20	•	•	3	3	0	X, Xc
Methyl alcohol	CH_3OH		20	•	•	0 ²⁾	0 ²⁾	0	all
Methyl alcohol	CH_3OH		Kp	•	•	0 ²⁾	0 ²⁾	0	all
Methylene chloride	CH_2Cl_2		20	•	•	1	1	0	Xc
Methylene chloride	CH_2Cl_2		Kp	•	•	1	1	0	Xc
Milk				•	•	2	2	0	X, Xc

Fluid	Chemical formulär	Concentration and temperature		Materials for seals		Metallic materials			Material code
		%	°C	KX-GT	TFM-1600	EN-ISO 1025 EN-G.LL 250	1.0619	1.4681	
Milk of lime	Ca(OH) ₂		20	•	•	0	0	0	all
Milk of lime	Ca(OH) ₂		Kp	•	•	0	0	0	all
Natrium acetate	CH ₃ COONa	20	20	•	•	1	1	0	all
Natural gas				•	•	1	0	0	all
Nitric acid	HNO ₃	10	20	•	•	3	3	0	X, Xc
Nitric acid	HNO ₃	10	Kp	•	•	3	3	0	X, Xc
Nitric acid	HNO ₃	40	20	•	•	3	3	0	X, Xc
Nitric acid	HNO ₃	40	Kp	•	•	3	3	0	X, Xc
Nitric acid	HNO ₃	konz.	20	–	•	3	3	0	X, Xc
Nitric acid	HNO ₃	konz.	Kp	–	•	3	2	1	X, Xc
Nitrogen	N ₂			•	•	0	0	0	all
Oils (lubricating oils, mineral)			20	•	•	0	0	0	all
Oils (vegetable)			20	•	•	0	0	0	all
Oleic acid	C ₁₇ H ₃₃ COOH			–	•	0	0	0	all
Oxalic acid	COOHCOOH			–	•	2	2	0	X, Xc
Oxygen	O ₂		20	•	•	0	0	0	all
Penthyl acetate	CH ₃ COOC ₅ H ₁₁			•	•	0	0	0	all
Petroleum ether			20	•	•	0	0	0	all
Phenol	C ₆ H ₅ OH			•	•	2	2	0	X, Xc
Phosphoric acid	H ₃ PO ₄	10	20	•	•	2	2	0	X, Xc
Phosphoric acid	H ₃ PO ₄	10	Kp	•	•	3	3	0	X, Xc
Phosphoric acid	H ₃ PO ₄	50	20	•	•	2	2	0	X, Xc
Phosphoric acid	H ₃ PO ₄	50	Kp	•	•	3	3	1	X, Xc
Phosphoric acid	H ₃ PO ₄	80	20	•	•	3	3	0	X, Xc
Phosphoric acid	H ₃ PO ₄	80	Kp	•	•	3	3	2	X, Xc
Potassium acetate	CH ₃ COOK		Kp	•	•	0	0	0	all
Potassium carbonate	K ₂ CO ₃	50	20	•	•	1	0	0	all
Potassium carbonate (potash)	K ₂ CO ₃		Kp	•	•	1	0	0	all
Potassium chlorate	KClO ₃		Kp	–	•	2	2	0	X, Xc
(at 100°, sat.sol)									
Potassium chromium sulphate	KCr(SO ₄) ₂ 12H ₂ O		20	•	•	–	–	0	X, Xc
Potassium chromium sulphate (chromic alum)	KCr(SO ₄) ₂ 12H ₂ O	25	Kp	•	•	–	–	3	
Potassium cyanide solution	KCN	5	20	• 5)	•	1	1	1	III, VIII, X, Xc
Potassium dichromate	K ₂ Cr ₂ O ₇		20	•	•	0	0	0	all
Potassium dichromate	K ₂ Cr ₂ O ₇		Kp	–	•	2	2	0	X, Xc
Potassium hydrochlorite	KOCl		20	•	•	2	2	1	X, Xc
Potassium hydrochlorite up to 20 g akt. Cl ₂ /l	KOCl		40	•	•	2	2	1	X, Xc
Potassium hydrogenartrate	COOH(CHOH) ₂		20	•	•	–	–	0	X, Xc
	COOK								
Potassium hydrogenartrate (at 100°, sat.sol)	COOH(CHOH) ₂		Kp	•	•	–	–	1	X, Xc
	COOK								
Potassium hydroxyde	KOH	25	20	•	•	0	0	0	all
Potassium hydroxyde	KOH	25	Kp	•	•	–	–	0	X, Xc
Potassium hydroxyde	KOH	50	20	•	•	0	0	0	all
Potassium hydroxyde	KOH		Kp	•	•	3	3	0	X, Xc
Potassium iodide	KJ	50	Kp	•	•	2	2	0	Xc
Potassium iodide	KJ			•	•	1	1	0	III, VIII, X, Xc
Potassium nitrate	KNO ₃		20	–	•	0	0	0	all
Potassium nitrate	KNO ₃		Kp	–	•	2	2	0	X, Xc
Potassium permanganate	KMnO ₄		20	•	•	0	0	0	all
Potassium permanganate	KMnO ₄		Kp	–	•	3	3	0	X, Xc
Propane	C ₃ H ₈		20	•	•	0	0	0	all



Fluid	Chemical formular	Concentration and temperature		Materials for seals		Metallic materials			Material code
		%	°C	KX-GT	TFM-1600	EN-1025 EN-619	1.0619	1.4581	
Salicylic acid	$C_6H_4OHCOOH$		20	•	•	2	2	0	X, Xc
Salpeter				•	•	0	0	0	all
Sea water			20	•	•	3	3	0	X, Xc
Sea water			Kp	•	•	3	3	0	X, Xc
Silicone oil				•	•	0	0	0	all
Soap				•	•	0	0	0	all
Sodium carbonate	Na_2CO_3		20	•	•	0	0	0	all
Sodium carbonate	Na_2CO_3		Kp	•	•	1	1	0	all
Sodium hydroxide	$NaOH$			•	•	0	0	0	all
Sodium hydroxide	$NaOH$	20	Kp	•	•	–	–	0	X, Xc
Sodium hydroxide	$NaOH$	35	20	•	•	0	0	0	all
Sodium hydroxide	$NaOH$	35	Kp	•	•	3	3	0	X, Xc
Sodium sulphate	Na_2SO_4			•	•	0	0	0	all
Sole	$NaCl$		20	•	•	3	3	1	X, Xc
Spinbath (up to 10% H ₂ SO ₄)			80	•	•	3	3	0	X, Xc
Starch solution				•	•	2	2	0	X, Xc
Steam (water vapour)				•	• ⁵⁾	0	0	0	all
Stearic acid	$C_{17}H_{35}COOH$			•	•	2	2	0	X, Xc
Sugar			20	•	•	1	1	0	all
Sugar			80	•	•	1	1	0	all
Sulphite lye (fresh cooking liquoor, spend liquoor)	$Ca(HSO_3)_2$		20	•	•	–	–	0	X, Xc
Sulphite lye (fresh cooking liquoor, spend liquoor)	$Ca(HSO_3)_2$		80	•	•	–	–	0	X, Xc
Sulphuric acid	H_2SO_4	1	20	•	•	3	3	0	X, Xc
Sulphuric acid	H_2SO_4	10	20	•	•	3	3	0	X, Xc
Sulphuric acid	H_2SO_4	90	20	•	•	1	1	0	1)
Sulphuric acid	H_2SO_4	konz.	20	•	•	0	0	0	all*)
Sulphur dioxide	SO_2			•	•	3	3	0	X, Xc
Sulphurous acid (cold) sat.sol.	H_2SO_3			•	•	3	3	0	X, Xc
Tannic acid	$C_{76}H_{52}O_{46}$	10	20	•	•	2	2	0	X, Xc
Tannic acid	$C_{76}H_{52}O_{46}$	10	Kp	•	•	3	3	0	X, Xc
Tannic acid	$C_{76}H_{52}O_{46}$	50	20	•	•	2	2	0	X, Xc
Tar (neutral)			180	•	•	1	1	0	III, VII, X, Xc
Tartaric acid	$(CHOHCOOH)_2$		20	•	•	2	2	0	X, Xc
Toluol	$C_6H_5CH_3$		20	•	•	0	0	0	all
Trichlorethylene	C_2HCl_3			•	•	1	1	0	all
Turpentine oil			20	•	•	0	0	0	all
Urea	$(NH_2)_2CO$		20	•	•	1	1	0	all
Water (fresh- a. drinking water)	H_2O			•	•	0	0	0	all
Water glass (K- and Na-silicate)	$K_2SiO_3Na_2HCl_3$			•	•	0	0	0	all
Xylene	$C_6H_4(CH_3)_2$		20	•	•	0	0	0	all

1) Piston and piston shaft in 1.4404 (please specify when ordering).
 2) Discoloration may occur.
 3) With heat-transfer media please inquire in our Gumpoldskirchen factory regarding choice of valve

rings. Please state the type of medium and the temperature range. Cast iron is chemically resistant to heat transfer media but, in view of the ability of these media to penetrate the pores, it is not recommended

4) All ferrous materials are resistant to hydrogen; it is pointed out, however, that hydrogen diffuses through cast iron and can cause embrittlement.
 5) 150 °C

Types of KVN valves



KVN 10-50, VIII cast steel



KVN 65-200, VIII cast steel



KVN 65-150, III cast iron



KVN 10-50, Xc stainless steel



KVMN 1/2"-2", VIII cast steel



KVN ANSI, VIII cast steel



KLINGER product range

Product range

Ballostar® KHA

3-piece ball valve made of grey cast iron, steel and stainless steel

Ballostar® KHI

2-piece ball valve with trunnion mounted ball, made of cast steel, steel and stainless steel

Ballostar® KHE

2-piece ball valve with floating ball, made of steel and stainless steel

Monolith KHO

One-piece fully welded ball valve made of steel

KLINGER Monoball®

One-piece ball valve made of steel and stainless cast steel

KLINGER Ball-o-top

Brass ball valves

Piston valves KVN

made of grey cast iron, spheroidal cast iron, steel and stainless cast steel

KLINGERMATIC®

Actuator for piston valves and ball valves

Liquid level gauges

for steam boiler and process application, reflex and transparent

Reflex and transparent glasses

Circular sight-glasses

AB cocks

Packing-sleeve cocks and pressure-gauge cocks in brass, steel and stainless steel



Key role

Link

Innovation

Navigation

Growth

Efficiency

Routine

KLINGER Fluid Control GmbH
A-2352 Gumpoldskirchen, Austria
Postfach 19, Am Kanal 8–10
Tel. +43 (0)2252-600-0
Fax +43 (0)2252-600-359
e-mail: office@klinger.kfc.at
www.klinger.kfc.at