

XOMOX[®]

brands you trust.



XLD - Lined Butterfly Valve Series

CRANE[®]

ChemPharma Flow Solutions

www.cranepharmasolutions.com

PERFORMANCE We listened to our most demanding critics: Our customers. Here's our response.

ANSI Class 150/PN10 valve design!



• **Lower torque ratings**

enable the use of smaller, less expensive actuators

• **The seal to atmosphere**

is assured by using the triple FKM O-rings around the base of the shaft

• **A wide sealing face**

prevents leakage at the flange

• **Improved disc design**

assures better stability

• **Temperature Range**

0° to 400° F
253K to 493K
-4° F to 392° F

• **Pressure Range**

Suitable for vacuum service
(0.02 psi/1,33 hPa)
Shut-off Pressure max. 150 psi/10 bar

• **ISO 5211 Mounting Pad**

Allows the option of bracket or direct mounting of operators.
Direct mounting ensures robust performance while providing compact system design.

• **Both the body and the shaft lining**

continue past the FKM-ring stem sealing components. The shaft and the seal components are protected from the flow media .

• **Better atmospheric corrosion resistance**

through high-end surface coating.

• **Materials**

Body and Disc in EN-JS1049 / ASTM A395 Ductile Iron, PFA / Teflon® Lined.

SAFETY You benefit... when experience meets design

Belleveille disc springs

provide live loading to ensure a tight top seal.

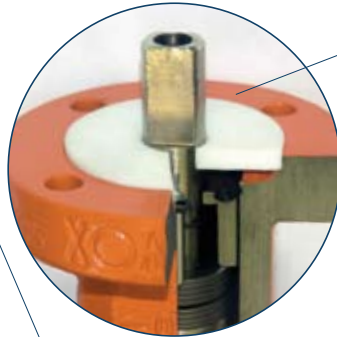

The revolutionary PTFE atmosphere seal protects the top seal components and the shaft from atmospheric corrosion.

Safety adjustment Packing Option

Upon request

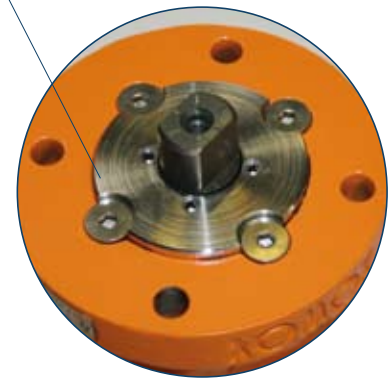

Blow-out proof design

Stem and disc are one simple part combined with the anti-blow-out system. (API 609 compliant.)

The extended body lining

assures optimum protection of the FKM-rings from corrosive media. These components are located behind the body liner extension. They are isolated from the media.



Triple FKM-ring backup-seals

provide a second, third and fourth line of protection against atmospheric leakage.

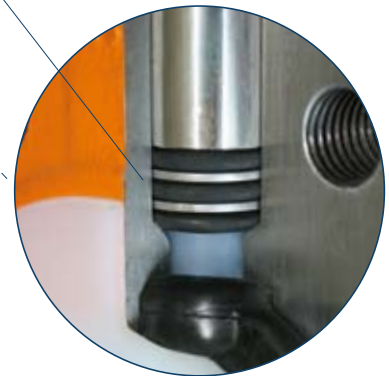

The in-line resilient seal assembly

assures optimum pressure distribution of the body liner to the disc assembly, providing tight sealing under all operating conditions. The wider seal-band provides a broader sealing area.

Fully lined bottom shaft

assures optimum corrosion resistance and eliminates a potential leakage path.

Product naming

XLD Series	Body	Flange
XLD11	WAFER	ANSI
XLD12		DIN
XLD13		JIS
XLD21	LUG	ANSI
XLD22		DIN
XLD23		JIS

DIMENSIONS Butterfly Valve XLD

All dimensions in inches

Valve Size	A	B	C	D	E	F	ØG	I	J	ØK	L	M	ØP	ØR	SW	ISO 5211
2"	1.69	3.19	5.24	1.18	6.42	0.12	3.94	6.61	4.69	0.63	0.98	M6	2.76	0.35	0.44	F07
3"	1.81	4.02	6.30	0.87	7.17	0.12	5.00	8.78	5.43	0.63	0.67	M6	2.76	0.35	0.44	F07
4"	2.05	4.72	6.69	1.02	7.72	0.12	6.02	10.51	6.06	0.63	0.83	M6	2.76	0.35	0.44	F07
5"	2.20	5.31	7.28	1.14	8.43	0.12	7.24	11.61	6.54	0.63	0.94	M6	2.76	0.35	0.44	F07
6"	2.20	5.71	7.99	0.98	8.98	0.12	8.35	12.64	7.09	1.00	0.79	M8	4.02	0.43	0.69	F10
8"	2.36	7.48	9.06	1.02	10.08	0.12	10.43	15.51	8.27	1.25	0.83	M8	4.02	0.43	0.81	F10
10"	2.68	9.17	10.16	1.02	11.18	0.12	12.76	18.19	9.09	1.25	0.83	M8	4.02	0.43	0.81	F10
12"	3.07	10.16	11.34	1.18	12.52	0.12	14.72	21.73	10.47	1.25	0.98	M8	4.92	0.55	0.81	F12
14"	3.62	13.90	16.42	1.50	17.91	0.12	17.52	22.68	13.58	1.42	1.38	M8	5.51	0.71	1.06	F14
16"	4.02	15.51	17.80	1.50	19.29	0.12	19.69	25.20	14.96	1.42	1.38	M8	5.51	0.71	1.06	F14
18"	4.49	16.14	18.50	2.36	20.87	0.20	22.05	26.61	15.47	1.89	2.17	M12	6.50	0.87	1.42	F16
20"	5.00	18.11	19.68	2.36	22.05	0.20	24.41	29.13	16.65	1.89	2.17	M12	6.50	0.87	1.42	F16
24"	6.06	20.47	22.05	2.56	24.61	0.20	28.03	34.65	18.43	2.36	2.44	M12	6.50	0.87	1.81	F16

All dimensions in mm

Valve Size	A	B	C	D	E	F	ØG	I	J	ØK	L	M	ØP	ØR	SW	ISO 5211
DN 50	43	81	133	30	163	3	100	168	119	15.9	25	M6	70	9	11.1	F07
DN 65	46	87	146	30	176	3	128	175	135	15.9	25	M6	70	9	11.1	F07
DN 80	46	102	160	22	182	3	127	223	138	15.9	17	M6	70	9	11.1	F07
DN 100	52	120	170	26	196	3	153	267	154	15.9	21	M6	70	9	11	F07
DN 125	56	135	185	29	214	3	184	295	166	15.9	24	M6	70	9	11.05	F07
DN 150	56	145	203	25	228	3	212	321	180	25.4	20	M8	102	11	17.5	F10
DN 200	60	190	230	26	256	3	265	394	210	31.8	21	M8	102	11	20.6	F10
DN 250	68	233	258	26	284	3	324	462	231	31.8	21	M8	102	11	20.6	F10
DN 300	78	258	288	30	318	3	374	552	266	31.8	25	M8	125	14	20.5	F12
DN 350	92	353	417	38	455	3	445	576	345	36	35	M8	140	18	27	F14
DN 400	102	394	452	38	490	3	500	640	380	36	35	M8	140	18	27	F14
DN 450	114	410	470	60	530	5	560	676	393	48	55	M12	165	22	36	F16
DN 500	127	460	500	60	560	5	620	740	423	48	55	M12	165	22	36	F16
DN 600	154	520	560	65	625	5	712	880	468	60	62	M12	165	22	46	F16

DIMENSIONS Butterfly Valve XLD

DN 50-300

2" - 12"

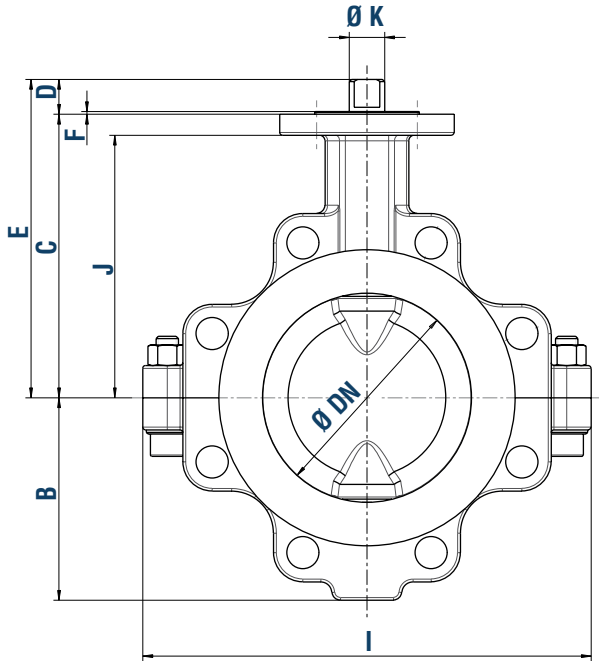

DN 350-600

14" - 24"

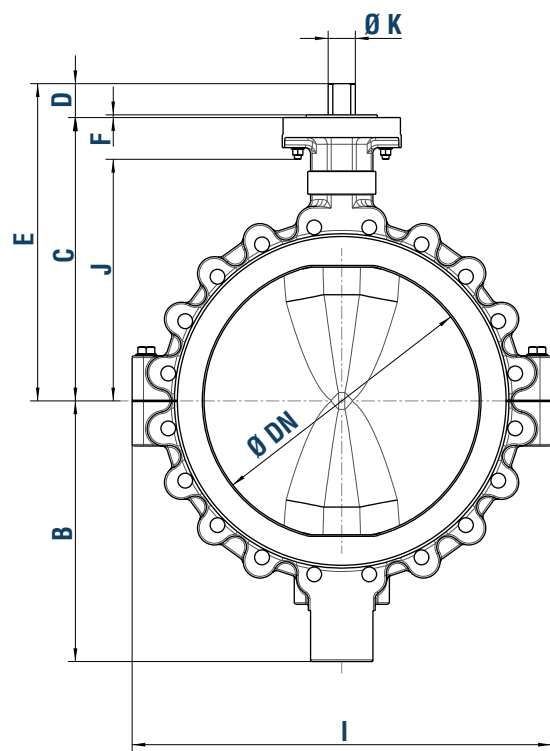

DN 50-600

2" - 24"

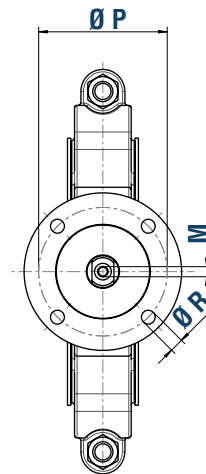
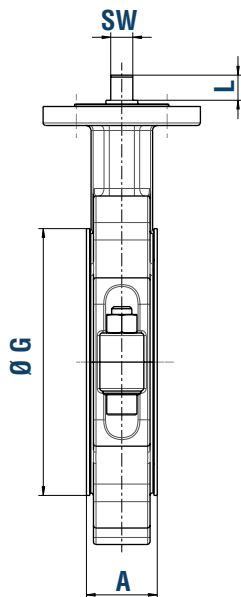

TECHNICAL DATA Flange bolt dimensions

Drilling DIN PN 10 (all dimensions in mm)

Valve Size	XLD 10 / 16 Wafer Style			XLD 22 Lug Style		
	F	G	H	F	G	H
DN 50	125	4	18	125	4	M16
DN 65	145	4	18	145	4	M16
DN 80	160	8	18	160	8	M16
DN 100	180	8	18	180	8	M16
DN 125	210	8	18	210	8	M16
DN 150	240	8	22	240	8	M20
DN 200	295	8/12	22	295	8/12	M20
DN 250	350/355	12	22/26	350/355	12	M20/24
DN 300	400/410	12	22/26	400/410	12	M20/24
DN 350	460	16	22	460	16	M20
DN 400	515	16	26	515	16	M24
DN 450	565	20	26	565	20	M24
DN 500	620	20	26	620	20	M24
DN 600	725	20	29	725	20	M27

Drilling JIS 10 K (all dimensions in mm)

Valve Size	XLD 13 Wafer Style			XLD 23 Lug Style		
	F	G	H	F	G	H
DN 50	120	4	19	120	4	M16
DN 65	140	4	19	140	4	M16
DN 80	150	8	19	150	8	M16
DN 100	175	8	19	175	8	M16
DN 125	210	8	23	210	8	M20
DN 150	240	8	23	240	8	M20
DN 200	290	12	23	290	12	M20
DN 250	355	12	25	355	12	M22
DN 300	400	12+4	25/22	400	16	M22
DN 350	445	16	25	445	16	M22
DN 400	510	16	27	510	16	M24
DN 450	565	20	27	565	20	M24
DN 500	620	20	27	620	20	M24
DN 600						

Drilling ANSI Pressure Class 150 (all dimensions in inches)

Valve Size	XLD 11 Wafer Style			XLD 21 Lug Style		
	F	G	H	F	G	H
2"	4.75	4	0.75	4.75	4	5/8-11
3"	6	4	0.75	6	4	5/8-11
4"	7.5	8	0.75	7.5	8	5/8-11
5"	8.5	8	0.88	8.5	8	3/4-10
6"	9.5	8	0.88	9.5	8	3/4-10
8"	11.75	8	0.88	11.75	8	3/4-10
10"	14.25	12	1	14.25	12	7/8-9
12"	17	12	1	17	12	7/8-9
14"	18.75	12	1.13	18.75	12	1-8
16"	21.25	16	1.15	21.25	16	1-8
18"	22.75	16	1.25	22.75	16	1 1/8-8
20"	25	20	1.25	25	20	1 1/8-8
24"	29.5	20	1.37	29.5	20	1 1/4-8

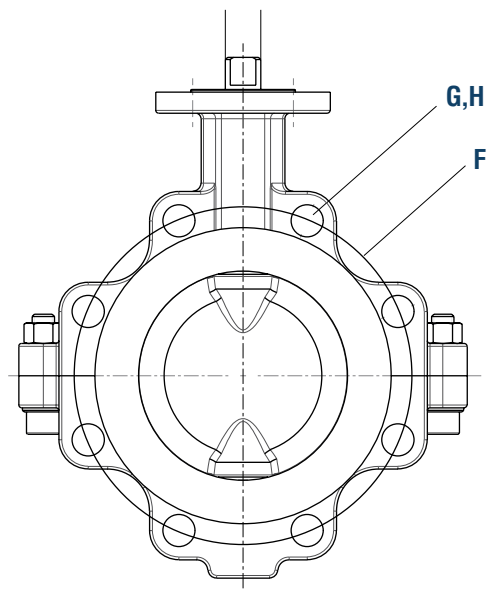

F: Hole Circle
G: Number of Holes/Threads
H: Diameter of Hole/Thread Dimension

DIMENSIONS with latching lever

All Dimensions in mm/inches

DN/Size	50/2"	65/2.5"	80/3"	100/4"	125/5"	150/6"	200/8"
A	173/6.81	186/7.32	192/7.56	208/8.19	225/8.86	245/9.65	301/11.85
B	356/14.02	356/14.02	356/14.02	356/14.02	356/14.02	432/17.01	432/17.01
C	134/5.28	134/5.28	134/5.28	134/5.28	134/5.28	134/5.28	134/5.28
D	89/3.50	89/3.50	89/3.50	89/3.50	89/3.50	89/3.50	89/3.50
weight in kg/lbs	8.5/18.74	9/19.84	9.5/20.94	11.5/25.35	14/30.86	17.5/38.58	27.5/60.63

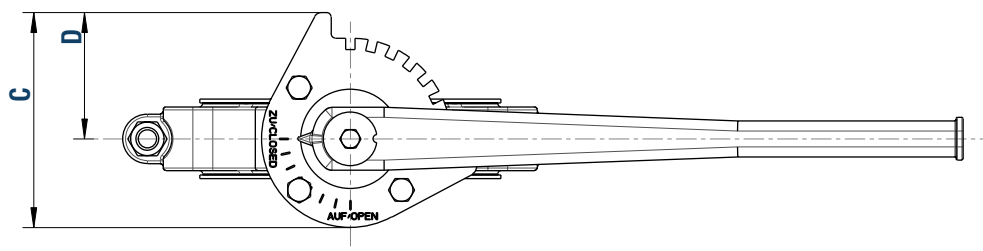
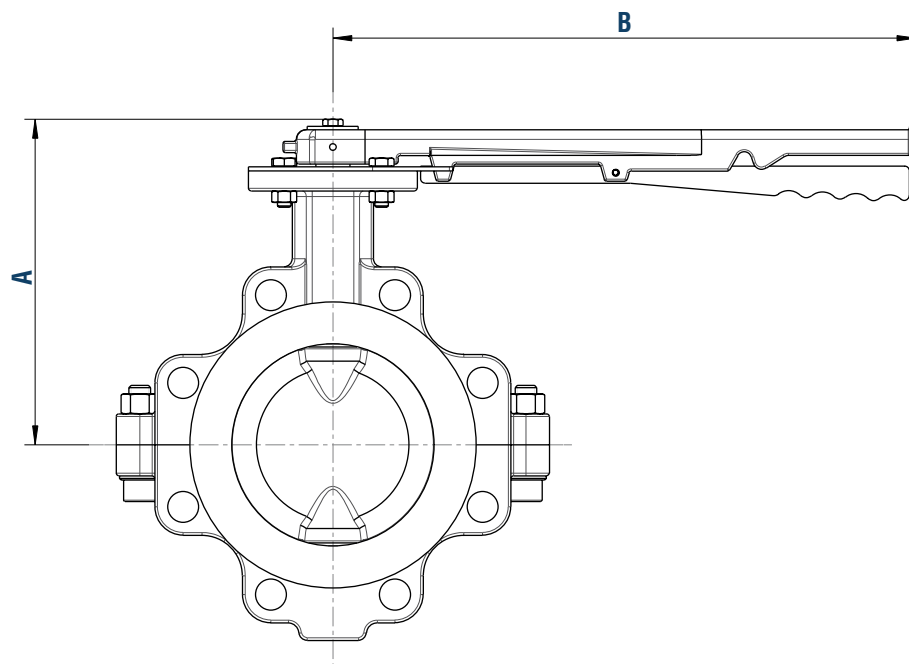

DIMENSIONS with gear

All Dimensions in mm/inches

DN/Size	50/2"	65/2.5"	80/3"	100/4"	125/5"	150/6"	200/8"	250/10"	300/12"
ØE	125/4.92	125/4.93	125/4.94	125/4.95	125/4.96	203/7.99	203/7.100	203/7.101	203/7.102
F	38.5/1.52	38.5/1.53	38.5/1.54	38.5/1.55	38.5/1.56	46.5/1.83	60/2.36	60/2.37	60/2.38
G	188/7.40	201/7.91	207/8.15	223/8.78	241/9.49	260/10.24	289/11.83	314/12.36	401/15.79
H	163/6.42	173/6.81	179/7.05	196/7.72	211/8.31	228/8.98	257/10.12	283/11.14	369/14.53
J	134/5.28	134/5.29	134/5.30	134/5.31	134/5.32	180/7.09	205.5/8.09	205.5/8.09	205.5/8.09
weight in kg/lbs	8/17.64	8.5/18.74	9/19.84	11/24.25	13.5/29.76	17.5/38.58	29.3/64.60	36/79.37	58/127.87

Dimensions with gear

DN 350-600, 14" - 24"

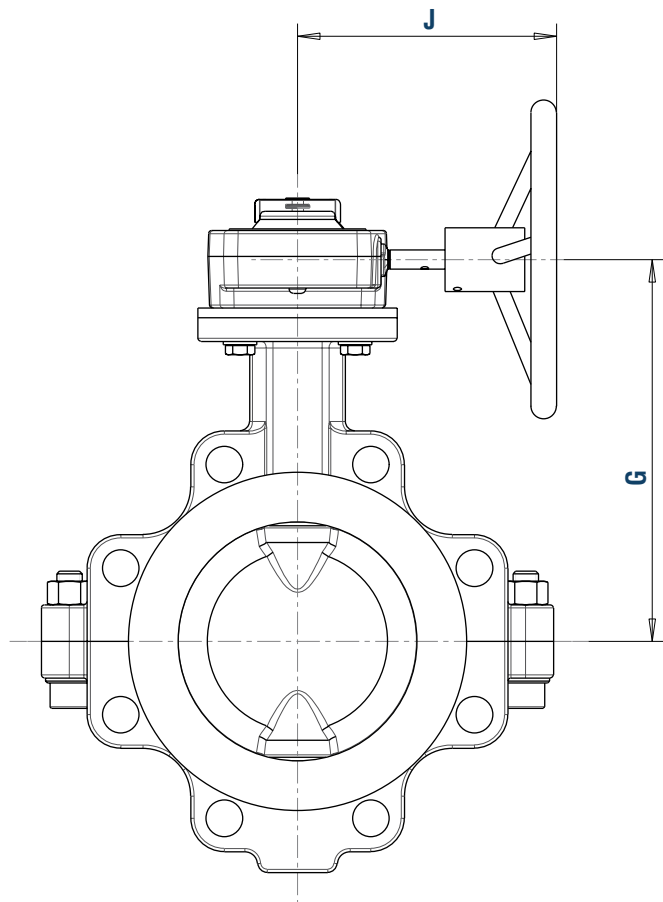
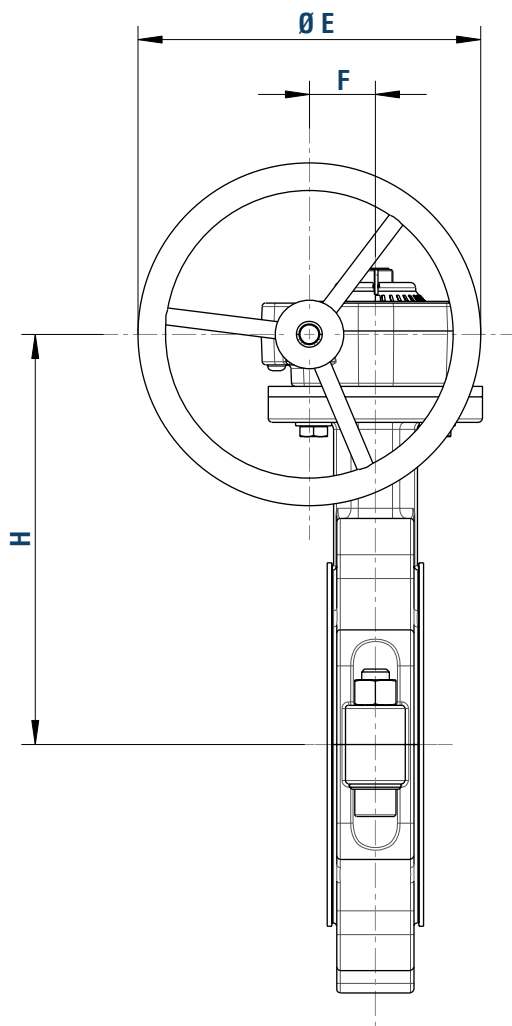

DIMENSIONS with gear

All Dimensions in mm/inches

DN/Size	350/14"	400/16"	450/18"	500/20"	600/24"
ØE	457/17.99	457/17.100	457/17.101	457/17.102	610/24.02
F	66.7/2.63	66.7/2.64	89.5/3.52	89.5/3.53	89.5/3.54
G	498/19.61	533/20.98	563.5/22.19	563.5/22.20	653.5/25.73
H	459/18.07	594/23.39	520/20.47	593.5/23.35	610/24.02
J	223/8.78	494/19.45	278/10.94	278/10.94	310/12.20
weight in kg/lbs (incl.MG)	112/246.92	136/299.83	194/427.70	210/462.97	277/610.68

Dimensions with gear

DN 50 - 300, Sizes 2" - 12"

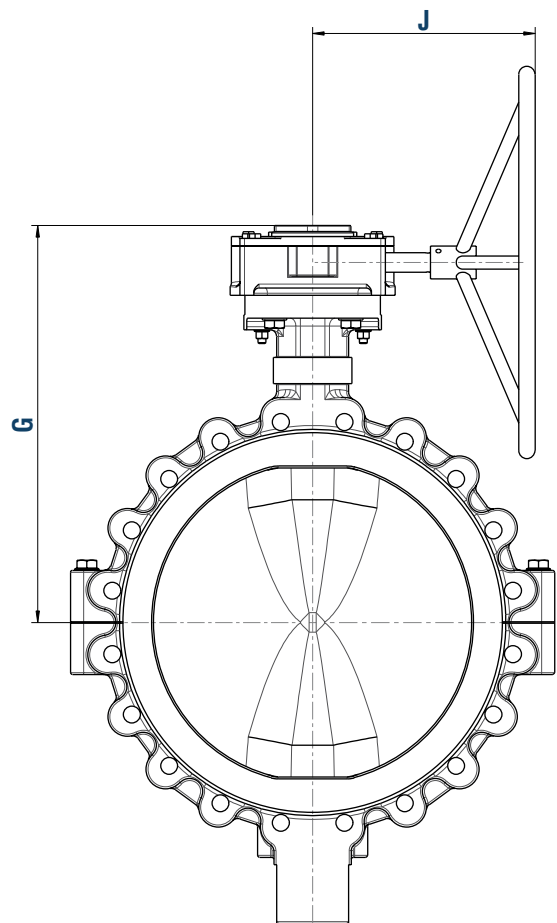
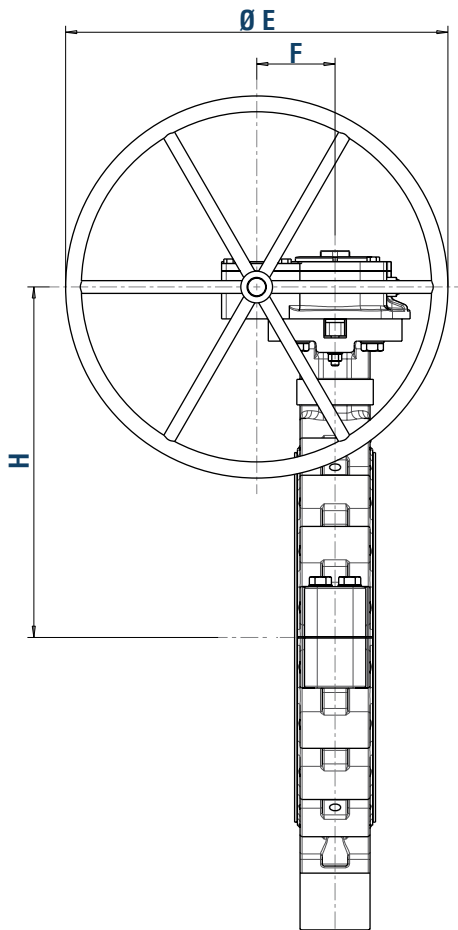

XLD Flow Characteristics

K_v values in m^3/h , $C_v=1.156 K_v$

ANGLE of aperture ANGLE of aperture (%)	0° 0	9° 10	18° 20	27° 30	36° 40	45° 50	54° 60	63° 70	72° 80	81° 90	90° 100
DN / NPS											
50 / 2"	0	0.62	2.6	12	30	65	95	135	165	170	180
80 / 3"	0	0.82	3.6	14.4	38	70	112	166	212	228	233
100 / 4"	0	1.5	5.8	22	55	102	177	296	408	464	486
125 / 5"	0	4.6	13	40	92	164	267	413	564	698	790
150 / 6"	0	12.12	31	82	183	296	415	595	834	1115	1445
200 / 8"	0	18.4	44	130	280	435	640	910	1282	1705	2227
250 / 10"	0	27.3	65	200	410	660	958	1345	1912	2550	3320
300 / 12"	0	40.7	99	295	596	965	1396	1975	2827	3795	4908
350 / 14"	0	68	216	413	720	1225	1944	2890	4104	5520	7200
400 / 16"	0	90	268	518	895	1535	2416	3663	5100	6960	8950
450 / 18"	0	116	340	660	1135	1934	3065	4610	6470	8810	13350
500 / 20"	0	164	415	822	1390	2400	3750	5670	7925	10700	13900
600 / 24"	0	231	570	1060	1900	3250	5130	7790	10830	14440	19000

DN 65 NPS 2.5" on request

Valve coefficients for process control: DN 50-200 / NPS 2-8

ANGLE of aperture Rated travel	9° 0.10	18° 0.20	27° 0.30	36° 0.40	45° 0.50	54° 0.60	63° 0.70	72° 0.80	81° 0.90	90° 1.00
Recovery Factor F_L	0.85	0.85	0.85	0.85	0.81	0.73	0.67	0.61	0.59	0.55
Factor F_L^2	0.72	0.72	0.72	0.72	0.66	0.53	0.45	0.37	0.35	0.30
Valve characteristic z_y	0.47	0.47	0.47	0.47	0.43	0.37	0.33	0.28	0.27	0.24
Pressure differential ratio κ_T	0.61	0.61	0.61	0.61	0.55	0.45	0.38	0.31	0.29	0.25
Valve style modifier F_d	0.08	0.15	0.23	0.31	0.38	0.45	0.52	0.58	0.64	0.70

Valve coefficients for process control: DN 250 - 600 / NPS 10-24

ANGLE of aperture Rated travel	9° 0.10	18° 0.20	27° 0.30	36° 0.40	45° 0.50	54° 0.60	63° 0.70	72° 0.80	81° 0.90	90° 1.00
Recovery Factor F_L	0.80	0.82	0.82	0.82	0.78	0.67	0.56	0.51	0.48	0.42
Factor F_L^2	0.64	0.67	0.67	0.67	0.61	0.45	0.31	0.26	0.23	0.18
Valve characteristic z_y	0.43	0.44	0.44	0.44	0.41	0.33	0.25	0.22	0.20	0.16
Pressure differential ratio κ_T	0.54	0.56	0.56	0.56	0.51	0.38	0.26	0.22	0.19	0.15
Valve style modifier F_d	0.08	0.15	0.23	0.31	0.38	0.45	0.52	0.58	0.64	0.70

XLD Pressure/Temperature Ratings & Valve Torques

XLD Pressure/Temperature Graph

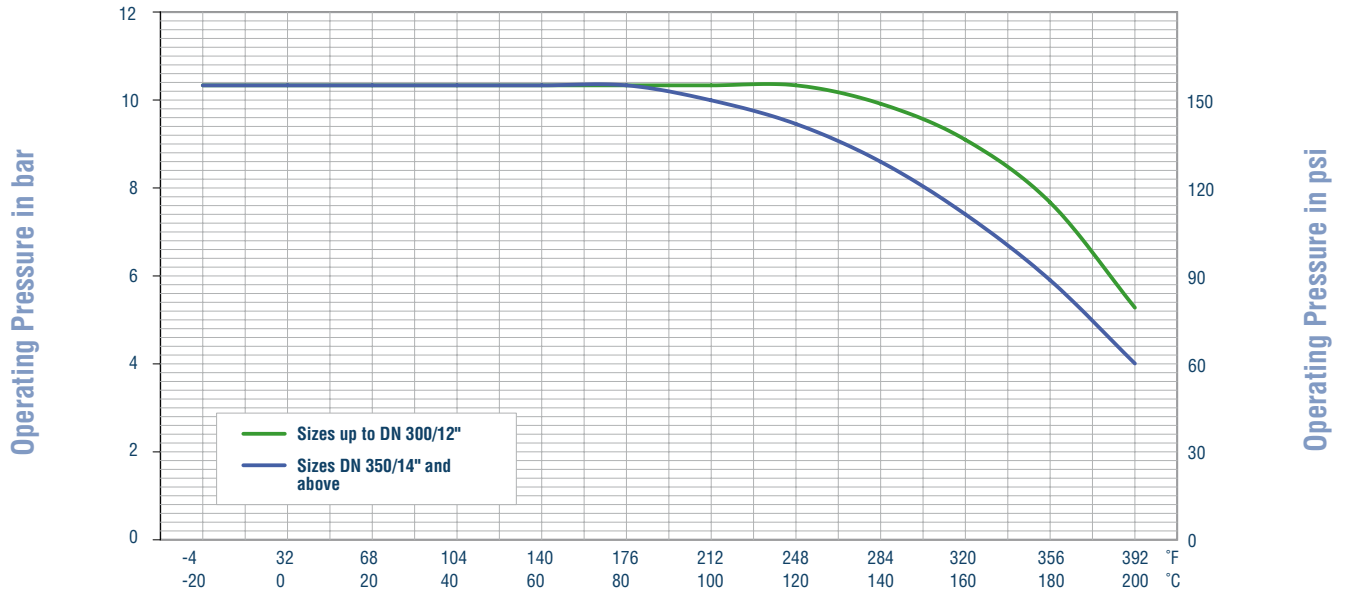

XLD Vacuum/Temperature Graph

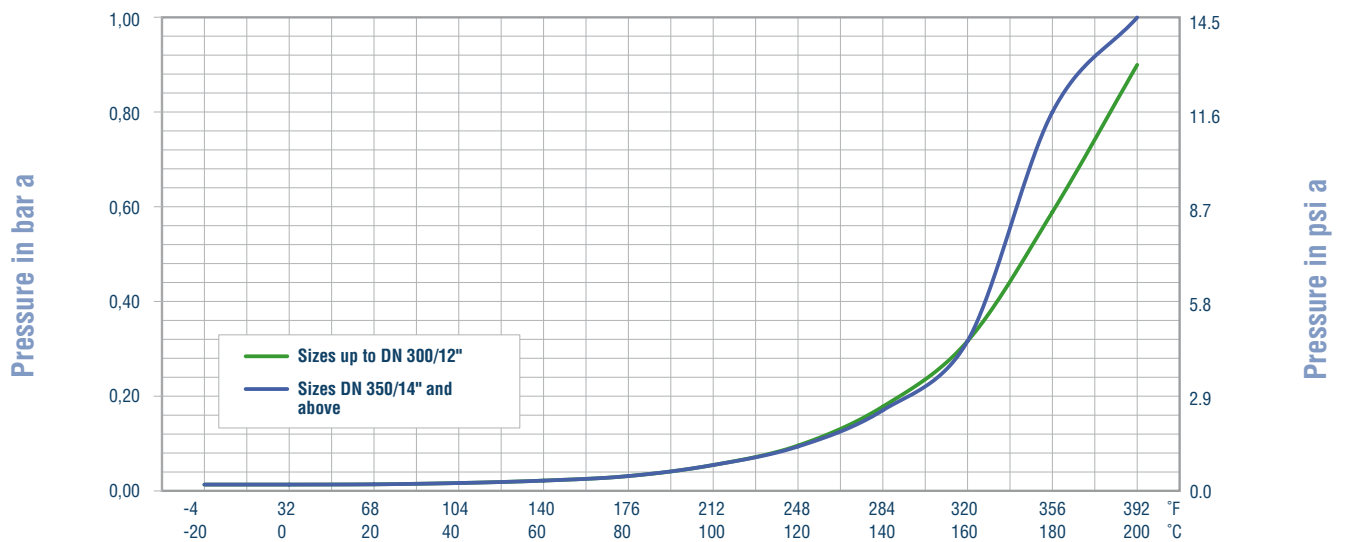

Valve Size		DN 50/2"	DN 80/3"	DN 100/4"	DN 125/5"	DN 150/6"	DN 200/8"	DN 250/10"	DN 300/12"	DN 350/14"	DN 400/16"	DN 450/18"	DN 500/20"	DN 600/24"
Break-away Torque *1	Nm	35	35	50	62	94	209	242	308	900	1300	1700	2700	4000
	in.lbs	310	310	443	549	832	1850	2142	2726	7966	11506	15046	23897	35403
Max. allowable Torque *2	Nm	162	162	162	162	296	628	628	628	2488	2488	2946	2946	5954
	in.lbs	1434	1434	1434	1434	2620	5558	5558	5558	22021	22021	26075	26075	52699

DN 65 NPS 2.5» on request

*1 Identical torque at opening and closing, running torque = 40% of break away torque. *2 Max. allowable torque with to EN-JS1049



Contact Information:

XOMOX International GmbH & Co.

Von-Behring-Str. 15
D-88131 Lindau / Germany
Telephone: (49) 8382-7020
Fax: (49) 8382-702144

XOMOX Cincinnati

4444 Cooper Road
Cincinnati, OH 45242
Telephone: (513) 745-6000
Fax: (513) 745-6086

CRANE

ChemPharma Flow Solutions

www.cranchempharma.com

brands you trust.

CRANE ChemPharma Flow Solutions Include: Pipes - Valves - Fittings - Actuators - Pumps

DEPA

ELRO

PSI
LINED PIPING SYSTEMS

RESISTOFLEX

ResistoPure

revo

Saunders
the science inside

XOMOX